



**TRAILMAX  
QUALITY,  
BACKED BY A  
5-YEAR  
STRUCTURAL  
WARRANTY**



- High Tensile Fabricated 4-beam Construction to Minimize Excess Frame Flex and Provide a More Safe and Stable Load
- Tubular Crossmembers on 12" Centers for Optimum Support of Concentrated Loads
- DOT Approved Sealed Beam, Rubber Isolated LED Lighting; Wiring Routed Through Tubular Construction to Protect from the Environment
- Shot Blasted Followed by a Phosphate Wash and Seal provides Clean Base of Paint Adhesion. Epoxy Primer and an Enamel Top coat for a Durable Finish
- Hydraulics to transition ramp to an 8° load angle (standard off self contained power unit – also available to run off wet kit))
- Available in various configurations including
  - Fifthwheel or tag configuration
  - Length configuration
  - Tandem or triple axle configuration
  - Various capacities available
- Various options available including
  - Wet kit in lieu of self contained power unit
  - D-rings or belt winches to specification
  - Outriggers
  - Hubometer
  - Custom paint & detail



**"For the Long Haul"**

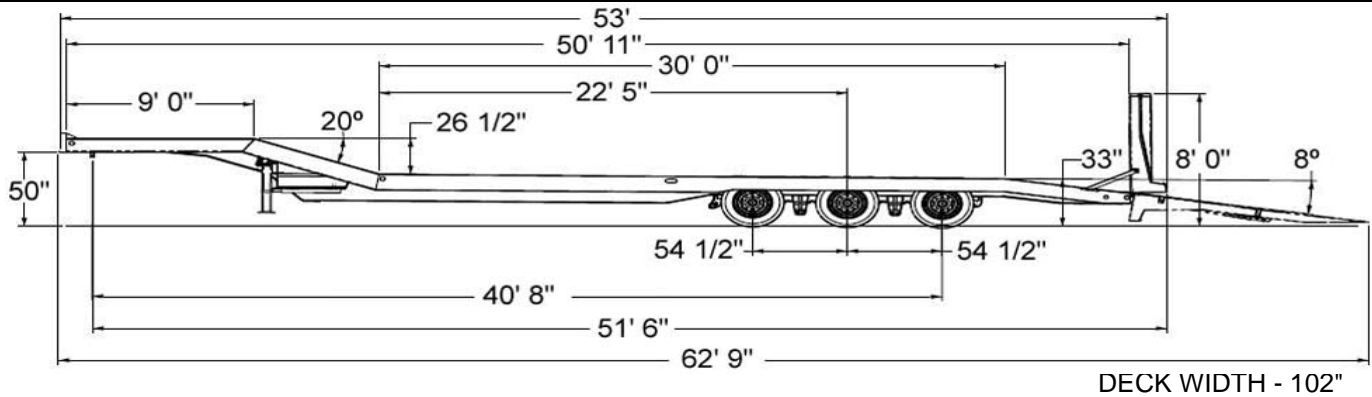

Capacity (Distributed)	100,000 lbs.
Concentrated Load	50,000 lbs. in 16'
Trailer Weight	20,660 lbs.
Frame Construction	Fabricated 4-beam design A-656 high tensile
Crossmembers	5" x 2" x 1/8" Tube and 4" x 2" x 1/8" Tube - ASTM A500B
Hitch	King Pin type 150,000 PSI ultimate strength, 115,000 yield
King Pin Setting	18"
Swing Clearance	82"
Loaded Deck Height	35"
Load Angle	8 degrees
Deck Width	102"
Landing Gear	2 Speed 70,000 lb., 100,000 lb. static load
Load Securement	2-way Chain Slot/Stake Pocket design
Hydraulic System	Self contained with 6 H.P. gas power unit
Axles	2 each 23,000 lb. capacity, 5 in. round 3/8" wall thickness, 71-1/2" track and 40" spring centers
Hubs	Oil bath type with Unimount Hub and drum, 8 on 275mm bolt circle
Brakes	12-1/4" x 7-1/2" s-cam full air brakes with maxi spring brakes on both axles, automatic slack adjusters, equipped with 2S 1M anti-lock braking system
Drums	Steel Outboard type
Suspension	Hutch H-9700 tri-axle with cast hangers and axle alignment capability
Wheels	17.5" x 6.75" Uni-mount 8 on 275mm bolt circle
Tires	215/75R 17.5 radial load range H
Finish Preparation	5 stage pre-treatment
Base Coating	DuPont two-component epoxy primer sealer
Finish Coating	DuPont two-component urethane enamel top coat
Electrical	Trucklite modular system with rubber isolated, sealed beam LED lighting, protected in tube construction
Decking	2 1/8" oak with fasteners at all cross members
Various Options	Spare Tire, Spare Tire Carrier, Apitong Decking, Traction Devices, D-rings, Belt Winches, 48" Underbody Toolbox, Custom Paint & Detail

Specifications are subject to change without notice

**Quality Trailers From Gem State Manufacturing, Inc.**

P.O. Box 987 ~ Caldwell ~ Idaho ~ 83606 ~ 1-800-447-0213 ~ 208-455-7551 ~ Fax: 208-455-7554

[www.trailmax.com](http://www.trailmax.com)