

Model FWTRD-100-PR

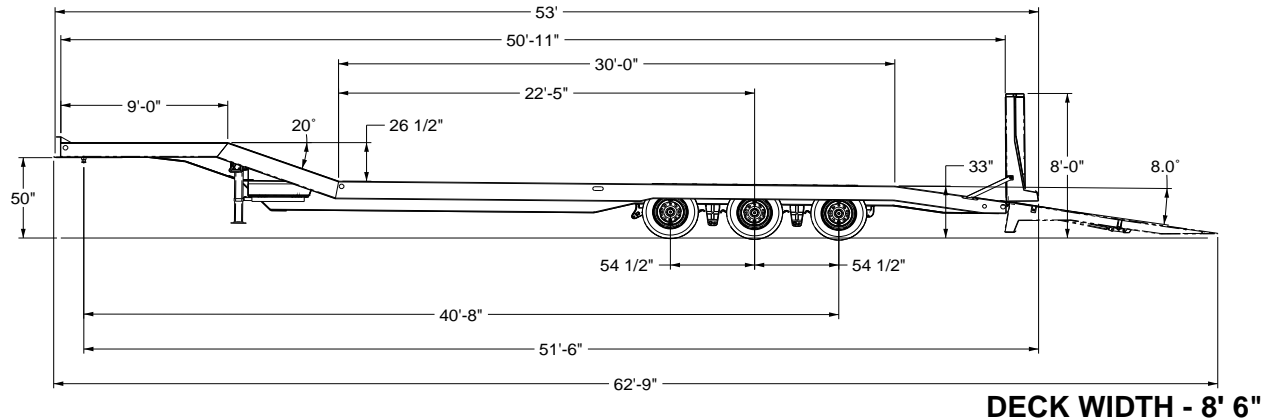

Gross Vehicle Weight Rating (G.V.W.R.) ----- 100,000 lbs.
Trailer Weight ----- 20,660 lbs.
Capacity @ 65 MPH (Uniformly Distributed) ----- 79,340 lbs.

FEATURES

- Hitch-** King Pin type 150,000 PSI ultimate strength, 115,000 yield
- Landing Gear-** 2 each, 2 speed landing gear, 35,000 lbs.capacity
- Load securement-** 22 each (11 per side) 2-way chain slot/stake pocket system
- Axles-** 3 each 18,000 lb. capacity each 5 in. round 1/2" wall thickness, 71 1/2" track on 40" spring centers
- Hubs-** Oil bath type with Stemco seals and oil cap, Uni-mount hub and drum, 8 on 275mm bolt circle
- Brakes-** 12 1/4" x 7 1/2" s-cam full air brakes with maxi spring brakes on three axles, automatic slack adjusters, equipped with 2S 2M anti-lock braking system
- Suspension-** Hutch H-9700 tri-axle with cast hangers and axle alignment capability
- Wheels-** 17.5" x 6.75" Uni-mount 8 on 275 bolt circle
- Tires-** 215/75R 17.5 radial load range H
- Electrical-** Trucklite modular system with rubber isolated, sealed beam lighting
- Decking-** 2 1/8" rough surface oak with fasteners at all cross members
- Paint-** Metal acid etched and phosphatized, epoxy primer coat and polyurethane top coat for a durable finish
- Ramp-** Hydraulically actuated with three-way valve, power up and down, spring center to hold position.

CONSTRUCTION

Main Frame and Perimeter Rails ----- High-Tensile Fabricated I-Beam Construction
Deck Cross Members ----- 5"x2"x1/8" Tube and 4"x2"x1/8" Tube - ASTM A500B

Engineered with top quality high tensile steel fabricated I-beam frame and cross members to minimize excess frame flex to provide a more stable and safe load. Heavy duty 4-beam construction with high tensile fabricated perimeter rails provide maximum strength for concentrated loads on outer edge of deck.

All specifications subject to change without notice

Quality Trailers From Gem State Manufacturing, Inc.

P.O. Box 987 • Caldwell • Idaho • 83606 • 1-800-447-0213 • (208) 455-7551 • Fax: (208) 455-7554

" For the Long Haul "