

Table of Contents

| | |
|---|-----------|
| Section 1. Operation | 3 |
| 1.0 Introduction | 3 |
| 1.1 Purpose | 3 |
| 1.2 Rating | 3 |
| 1.3 Design and Safety Factors | 4 |
| 1.4 Vehicle Load and Handling Limits | 4 |
| 1.5 Reporting Safety Defects | 7 |
| 1.6 Alert Symbols | 8 |
| 1.7 Pre-Trip Inspection | 9 |
| 1.8 Hook-Up Procedures | 10 |
| 1.9 Loading and Unloading | 11 |
| Trailers With Ramps | 12 |
| Trailers With Tilt Decks | 12 |
| Section 2. Maintenance | 13 |
| 2.0 Periodic Maintenance | 13 |
| 2.1 Structural Components | 14 |
| Sub-Frame | 14 |
| Deck | 14 |
| 2.2 Sub-Assembly Components | 14 |
| Coupling | 14 |
| Jack | 15 |
| Cushion Cylinder | 15 |
| Deck Latch | 15 |
| Deck Hinge Assembly | 15 |
| 2.3 Running Gear | 16 |
| Suspension | 16 |
| Hubs and Drums | 16 |
| Brake Drum Inspection | 17 |
| Bearing Inspection | 17 |
| Standard Bearing Lubrication | 18 |
| E-Z Lube Bearing Lubrication | 18 |
| Seal Inspection and Replacement | 19 |
| Hub Reinstallation and Bearing Adjustment | 19 |
| 2.4 Wheels and Tires | 20 |
| Wheels | 20 |
| Tires | 22 |
| Inflation Pressure | 22 |
| Tire Wear Diagnostic Chart | 23 |
| 2.5 Electrical | 24 |
| Harnesses and Lights | 24 |
| Junction Block | 24 |
| Electrical Plug | 24 |
| 2.6 Brake System (Common to Hydraulic and Electric) | 25 |

8012DT

| | | |
|-------------------|--|-----------|
| | Brake Adjustment | 25 |
| | Brake Cleaning and Inspection | 26 |
| | Brake Lubrication | 26 |
| 2.7 | Hydraulic Brake System | 27 |
| | Operation | 27 |
| | Surge Actuator Maintenance | 27 |
| | Corrosive Environment Warning | 28 |
| | Hydraulic Lines | 28 |
| | Hydraulic Brakes | 28 |
| | Brake System Bleeding | 29 |
| | Hydraulic Brake System Troubleshooting Chart | 31 |
| 2.8 | Electric Brake System | 31 |
| | Operation | 31 |
| | Using your Brakes Properly | 32 |
| | Synchronization | 33 |
| | Controllers | 33 |
| | Magnets | 34 |
| | Electric Brake System Troubleshooting | 35 |
| | Measuring Voltage | 35 |
| | Measuring Amperage | 37 |
| | Electric Brake System Troubleshooting Chart | 38 |
| 2.9 | Pre-Storage Maintenance | 40 |
| 2.10 | Pre-Season Maintenance | 41 |
| Section 3. | Parts | 42 |
| 3.1 | Structural Components | 42 |
| 3.2 | Major Sub-Assemblies | 45 |
| | Binkley Jack | 45 |
| | Couplers | 46 |
| 3.3 | Running Gear | 48 |
| | Hydraulic Brake Components | 50 |
| | Electric Brake Components, 7K | 52 |
| | Axle End Components | 54 |
| 3.4 | Wheels and Tires | 55 |
| 3.5 | Electrical | 56 |
| | Harnesses and Lights | 56 |
| | Electrical Plug | 58 |
| | Electric Brake Wiring | 59 |
| | Electric Breakaway System | 59 |
| 3.6 | Hydraulic System | 60 |
| | Hydraulic Lines | 60 |
| | Model DA20 Surge Actuator | 62 |
| | Power Unit Motor | 64 |
| | Power Unit Control Valve | 66 |
| | Power Unit Control Valve Schematic | 67 |
| | Gear Pump and Manifold Assembly Parts List | 68 |
| | Gear Pump and Manifold Assembly Parts Illustration | 69 |
| 3.7 | Tool Box | 70 |
| Section 4. | Warranty Claim Procedure | 72 |

Section 1. Operation

1.0 Introduction

This section describes how trailers can have different operational characteristics based on design, load configuration, gross weights, suspension characteristics, articulation and extreme differences between loaded and unloaded weights.

Trailers have safe operating limits just as automobiles, airplanes, and other vehicles. The interaction of the vehicle characteristics, maintenance, load, roadway, weather, the skill of the driver and vehicle speed affect these limits. Knowledge of how these factors affect the vehicle's operating limits and utilization of defensive driving techniques should result in safer driving.

1.1 Purpose

The purpose of this section is to describe how the vehicle characteristics, maintenance, road conditions, and weather can affect trailer control and stability limits, and how driver awareness and skill can help compensate for these factors. This knowledge will assist you to safely enjoy the maximum utility and productivity from your trailer.

First and foremost, **DO NOT** operate the trailer until you have read and fully understand this instruction and operating manual. It is also important that each and every person who operates the trailer be given the opportunity to read this manual.

1.2 Rating

Gross Axle Weight Rating (GAWR) is the rated load-carrying capacity of an individual axle and wheel assembly. It represents the load that may be steadily sustained by the components in the system; i.e., tires, wheels, hubs, bearings, axles, brakes, suspension, sub-frame, etc. with the GAWR limited by the component with the lowest working rating. Consideration of environmental and operational factors may require the manufacturer to reduce the nominal rating.

Gross Vehicle Weight Rating (GVWR) is the maximum rated combined weight of a trailer and its payload (uniformly distributed) based on its structural capabilities.

8012DT

1.3 Design and Safety Factors

The safety factor is a ratio between the design stress imposed by the load sitting static on the trailer and the minimum yield stress of the steel used in construction of that trailer structure. For example, if the structure is built using 50,000 psi minimum yield strength steel and the load sitting on it causes a stress level of 25,000 psi then a 2:1 safety factor would exist. THIS SAFETY FACTOR DOES NOT MEAN THAT THE STRUCTURE CAN THEN BE USED TO CARRY TWICE THE RATED LOAD. Under dynamic conditions, or as the trailer moves and encounters shocks, vibrations, twists and other conditions that exist during transport, stress levels are elevated far beyond those in the static situation.

Distributed Load is when a load is distributed evenly over the length of the trailer deck. This would be considered as the ideal load scenario when fully loaded to rated capacity.

Concentrated Load is one that is localized over a shorter than normal distance and imposes greater stress in the concentrated load areas. Under these conditions, it is not recommended to carry the full rated capacity of the trailer. Extreme concentrated applications may require additional support for the load.

1.4 Vehicle Load and Handling Limits

Vehicle handling limits can be greatly affected by the weight of a load, its placement, the amount of weight distributed over the axles and whether or not the load is secured properly.

Tow vehicle and trailer combinations are designed to provide maximum directional control and roll stability within the constraints of highway size and weight limits. Any combination can be rolled over by driving too fast around a curve, making too abrupt a maneuver, or by leaving the roadway. Locking up the wheels on an axle can result in a jackknife or trailer swing out.

One of the major contributing factors to vehicle rollover is high center of gravity on tall loads. Extreme caution should be used in maneuvering a vehicle and trailer combination, or any unit that has a tall load. Positioning the load in a central side to side location will enhance directional control, roll stability and braking.

You should be aware that trailers with a shorter wheel base are more prone to roll during an abrupt lane change or quick reactions at the wheel. This tendency can be made dramatically worse with a tall, high center of gravity load.

Overloading a vehicle should never be permitted. Overloading results in tire blow-outs, spring breakage, frame damage, diminished braking capacity, and will severely alter the vehicle's normal handling characteristics. All vehicles are designed with a maximum load capability. To best utilize these vehicles in the safest manner the loads as shown on the certificate label should not be exceeded.

Adequate tongue weight is required for trailers to tow correctly. Inadequate tongue weight can cause a "whipping action" particularly in shorter wheel base trailers. Too much tongue weight can overload tow vehicle hitch resulting in reduced steering load and loss of steering control. Selecting the correct tow vehicle is crucial for the application.

Always maintain enough braking and stopping distance. Erratic or unequal brake action from side to side on either tow vehicle or trailer can cause handling problems in braking situations. A balance between tow vehicle and trailer on brake application and release timing and synchronized pressure will reduce push/pull characteristics which when excessive, may result in jackknife. The use of properly matched brake lining is recommended to enhance safer braking.

Proper alignment of both tow vehicle and trailer wheels will add significantly to the handling characteristics of the combination and allow the driver to utilize all the design responses of the vehicle to make evasive maneuvers in the safest manner.

Irregular terrain, steep grades and crowned roads, especially rural roadways, freeways, exit ramps, curves, bumps and depressions introduce forces into a tow vehicle/trailer combination that could result in an accident if proper precautions and driving techniques are not followed. Even a vehicle that meets all maintenance and load requirements can become hazardous when excessive speeds and certain roadway characteristics are combined.

While on a downgrade, the force of gravity works against the driver in maintaining control of the vehicle, particularly if the road surface is wet or slick from snow and ice or loose material. On upgrades, the problem is spinning out due to insufficient traction at the drive wheels, particularly on snow and ice.

Great care must be taken to avoid excessive use of brakes on long downgrades. Overheated brakes are dangerously inefficient. It is very dangerous to brake on a downgrade using only the trailer brakes. If this is done, the trailer brakes heat up and fade and the tow vehicle brakes alone will not be able to stop the combination by themselves. Drivers should reduce speed, downshift and use engine compression as the principal means of controlling speed on long grades and using all brakes so brake temperatures can be held to a safe level.

8012DT

Weather conditions can be a major factor in the cause of accidents. Rain, ice, snow, high winds and visibility combined with excessive speed, sudden lane changes, or other factors that put lateral forces into a tow vehicle trailer combination contribute significantly to an accident.

Slippery roads can increase stopping distances and reduce the ability to control the vehicle. When the road is wet, the available tire/road friction may be half that of a dry road, and icy roads can reduce friction many times over wet roads. If hard braking or rapid acceleration occurs, there may be little or no friction available to prevent tire lateral movement and skidding results.

The driver has a responsibility to compensate for the characteristics and conditions of his vehicle, the road conditions and weather. Reducing speeds and increasing attentiveness may compensate for most of these conditions. The more familiar the driver is with the vehicle and the road, the less likely he will need to make abrupt emergency maneuvers which will take the vehicle to its limits. Control and stability may be maintained if the driver knows his vehicle, his load, and the road.

Either braking or accelerating while cornering can significantly reduce the controllability and stability of the vehicle and should be avoided. The best driving practice is to decelerate to a safe conservative speed before entering a corner or approaching congested traffic and then apply only moderate power until an essentially straight path has been established.

It is imperative that a safe speed always be maintained. The safe speed is that speed at which control can be maintained over the vehicle at all times. This speed will allow an emergency change of lane maneuver, travel off an exit ramp with a tightening radius and recovery from pavement drop-off or wet pavement. This speed will vary from one combination of vehicle to another and takes into consideration such factors as road conditions, weather, traffic, visibility, type of load and experience of the driver.

1.5 Reporting Safety Defects

If you believe that your vehicle has a defect that could cause a crash, injury, or death, you should immediately inform the National Highway Traffic Safety Administration (NHTSA) in addition to notifying Gem State Mfg., Inc.

If NHTSA receives similar complaints it may open an investigation, and if it finds that a safety defect exists in a group of vehicles it may pursue a remedy campaign and recall those vehicles. However, NHTSA cannot become involved in individual problems between you, your dealer, or Gem State Mfg., Inc.

To contact NHTSA, you may either call the Vehicle Safety Hotline toll free at 1-888-327-4236 (TTY: 1-800-424-9153), go to <http://www.safercar.gov>; or write to Administrator, NHTSA, 400 Seventh Street SW., Washington, DC 20590. You can also obtain other information about motor vehicle safety from <http://www.safercar.gov>.

1.6 Alert Symbols

It is important that you know the meaning of the following symbols that are used throughout this document.



SAFETY ALERT!

This is the safety alert symbol. It is used to alert you to potential personal injury hazards. Obey all safety messages that follow this symbol to avoid possible injury or death.



DANGER!

DANGER! indicates an imminently hazardous situation which, if not avoided, will result in death or serious injury.



WARNING!

WARNING indicates a potentially hazardous situation which, if not avoided, could result in death or serious injury.



CAUTION!

CAUTION indicates a potentially hazardous situation which, if not avoided, may result in minor or moderate injury.



CAUTION

CAUTION used without the safety alert symbol indicates a potentially hazardous situation which, if not avoided, may result in property damage.

1.7 Pre-Trip Inspection

There are some items on every vehicle combination that can be and should be inspected prior to every trip that require no special knowledge, training, or sophisticated equipment.

Before beginning a trip, make a thorough visual inspection of the trailer for cracks in the structure, or bent components such as the tongue or frame. Check for any missing fasteners in suspension as well as other areas, and look for broken or bent springs and spring hangers or otherwise damaged components.

Verify that the hitch on the tow vehicle is the correct size and configuration to fit the trailer coupling. The hitch must be rated to meet or exceed the Gross Vehicle Weight Rating (GVWR) of the trailer.

Check the hitch height of the trailer and compare it to the tow vehicle; it is very important that the trailer be towed in the level position when loaded. In order to achieve the correct hitch height, elevate the tongue of the trailer slightly (1" to 2") by adjusting the trailer hitch to compensate for settling of tow vehicle springs when loaded.

Always visually inspect hitch for unusual appearances such as bent components, cracks in welds or chipped paint where stress cracks may appear from high loads.

Check tires for proper inflation. Tire manufacturers recommend checking inflation pressure while trailer is not loaded and tires are cool. This will provide a more accurate reading. A drop of 10 PSI in tire pressure can reduce the carrying capacity of the tire as much as 20%. This reduced capacity could cause tire failure and poor tire life.

Maintaining proper wheel nut torque value is essential to prevent wheel end separation or potential damage to the hub or wheel. Always check wheel nuts every 50 to 100 miles for the first 200 miles of operation, then periodically thereafter. The same procedure should be repeated after dismount and remount of wheels. It is important to follow the specified tightening sequence recommended in the tire maintenance section of this manual.

NOTE: For trailers with hydraulic surge brakes, check the brake fluid reservoir level and add brake fluid to the fill line if necessary.

8012DT

1.8 Hook-Up Procedures

⚠WARNING TRAILER HOOK-UP

The consequences of not properly hooking the trailer to the tow vehicle can be very serious. Failure to adhere to information in this section could lead to the trailer becoming detached, the trailer brakes and/or lights not working correctly, or other unsafe situations which could result in an accident causing property damage, bodily injury or death.

Connect the tow vehicle to the trailer and check that the coupler is completely latched. Be sure that a safety pin is inserted to ensure coupler will not unlatch during transport.

Connect the electrical plug from the trailer's harness to the receptacle of the tow vehicle. Check all lights on the trailer to make sure they are working correctly with the tow vehicle's electrical system.

Be sure the landing leg and drop foot are fully retracted and the crank handle is stowed in transport position. For trailers with 2-speed jacks, use low gear for raising and lower the jack under load, and high gear for raising and lowering the leg when it is off the ground.

Check all safety chains and their attachment to both the trailer and the towing vehicle. Connect safety chains to tow vehicle using crossed pattern under tongue. Allow slack for turning, but avoid having chains drag on pavement. Make certain that all attachment devices are properly installed and in good working order.

For trailers with air brakes, connect the Glad Hands (one service and one emergency) to tow vehicle. Shut off petcock(s) on air tank(s) or if already shut, open to exhaust all moisture, then shut off. It is very important that the air system be drained of moisture after each use to keep all components functioning properly and to make equipment safe.

Trailers with electric brakes or hydraulic surge brakes come equipped with an emergency breakaway device. The breakaway system is designed to operate after the coupling system has failed. Connect breakaway chain S-hook to bumper or hitch on tow vehicle. Allow slack for turning, but avoid letting chain drag on pavement. Provide as straight a connection as possible.

Always check that trailer brakes are working properly. If trailer is equipped with electric brakes, use brake controller to adjust for load.

The breakaway system is for emergencies and is not a parking brake.

The following paragraphs pertain to trailers with hydraulic surge brakes:

Operation

TRAILMAX®

The 'surge' or 'push' of the trailer toward the tow vehicle when the tow vehicle brakes are applied actuates the trailer brakes. Excessive surge actuator travel (over one inch) when brakes are applied indicates a need to adjust the trailer brakes.

Should the breakaway be accidentally applied while unhitching, pry the breakaway locks apart to release lever.

Sway control devices that restrict operation of the actuator cannot be used. The actuator must be free to telescope in response to braking requirements.

1.9 Loading and Unloading

CAUTION

TRAILER LOADING PRACTICES

The consequences of ignoring proper trailer loading practices can be very serious. Failure to adhere to the information in this section could lead to unsafe handling, diminished braking capacity, or other unstable trailer characteristics which could result in an accident causing property damage, bodily injury or death.

It is the operators responsibility to take whatever steps necessary to load the trailer properly, even when it is not easy to calculate the total load or determine the load center of gravity.

A decal on the trailer similar to the one shown below indicates the correct placement of the load. Load the trailer so that 60% of the total load weight is forward of the arrow, and 40% is rearward of the arrow. This will ensure that the proper load balance and tongue weight are achieved.

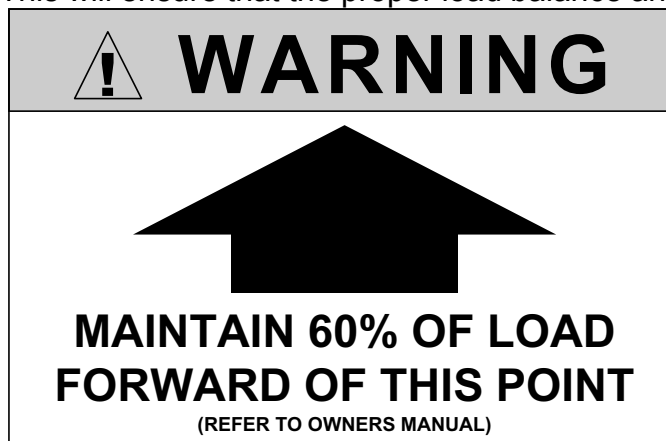

CAUTION

ADVERSE WEATHER CONDITIONS!

Adverse weather conditions can cause wet and slippery trailer decks and ramps. Depending on the type of equipment and typical weather conditions it may be necessary to add traction aids to the trailer deck and ramps.

8012DT

Always use extreme caution when loading and unloading equipment on trailer. Make sure road surface is level. Loading and unloading on an uneven surface may cause damage to the trailer frame and create unsafe loading conditions.

Always set brakes on tow vehicle and trailer before loading and unloading and use chock blocks as an added safety precaution.

Before securing equipment, always lower booms, loaders and buckets. The parking brake on the equipment being transported must be engaged, where applicable. Always make sure you are under the maximum allowable height clearance.

Equipment with crawler tracks as well as wheel type equipment should be restrained in the lateral, forward, rearward and vertical direction using a minimum of four direct tie-downs and binders each having a working load limit of at least 5000 lbs. and should be blocked to prevent forward movement.

Articulated vehicles shall be restrained in a manner that prevents articulation while in transit.

Trailers With Ramps

Loading ramps can be adjusted for various track widths. Prior to loading or unloading it is very important that ramps are adjusted to proper spacing for equipment being transported. When loading equipment onto deck, drive slowly forward until appropriate tongue load is achieved. Ramps are designed to support rear of trailer during loading and unloading. Ramps must be in stored position during transport.

Trailers With Tilt Decks

It is very important that the deck latch is in the locked position with the safety pin inserted at all times during transport. Always unlock deck when unloading equipment. Failure to do this may result in damage to deck. Deck latch is adjustable to keep deck tight and rattle free.

When loading equipment onto deck, drive slowly until deck begins to tilt closed, and proceed forward until 10% of load weight in on the hitch of trailer. Not enough tongue weight can result in swaying of trailer, which can be an unsafe condition.

When unloading use reverse procedure as loading. Back up slowly until deck begins to tilt, stop and wait for deck to completely open, then proceed to back off slowly.

Trailer deck will tilt open and tilt closed with one persons weight. The deck may tilt faster or slower depending on outside temperature, because the temperature affects the density of the fluid in the deck cylinder.

Section 2. Maintenance

2.0 Periodic Maintenance

Pre-Trip Inspection-

Check brake fluid level- see 'Surge Actuator Maintenance' on page 27.

Lube coupler- see 'Coupling' on page 13.

Examine frame and tongue members for evidence of damage or cracked welds.

Check lights for correct operation.

Weekly-

Check cold tire pressures- see 'Inflation Pressure' on page 22.

Check lug nut torque- see page 21.

Monthly-

Check for loose or missing suspension fasteners.

Check brake adjustment- see page 25.

Quarterly-

Lube Demco surge actuator rollers- see 'Surge Actuator Maintenance' on page 27.

Annually-

Pack wheel bearings- see page 18.

Inspect brakes and linings- see page 26.

Bi-annually-

Flush brake fluid and bleed system- see page 29.

Grease deck hinge- see page 15.

Special-

Submerged axles- immediately re-pack wheel bearings. Check brake linings for contamination.

Accident or Overload- check all structural components for damage. Check tires and wheels for damage.

Skidding-check tires for flat spots.

8012DT

2.1 Structural Components

Sub-Frame

Other than for periodic or special inspections the trailer sub-frame requires no regular maintenance other than washing. Keeping the trailer clean will help you notice other things such as cracked welds or leaking brake fluid. If your application requires the hauling of corrosives then frequent washdowns are very important.

Deck

The deck is the major load-carrying member of the trailer. It requires no regular maintenance other than a periodic check for broken welds, loose fasteners and corrosion. If the trailer has been overloaded or in an accident, inspect the deck carefully.

Your trailer has one of two types of decking material, either rubber compound or wood. For wood decks it may be necessary to apply a new coat of wood preservative after decking has aged and become dry. The best time to apply preservative is during warm weather for better penetration.

The rubber compound material requires no particular maintenance.

Replace decking when necessary. Occasionally check for loose, missing, or broken deck screws.

2.2 Sub-Assembly Components

Coupling

Your trailer has either a pintle eye or ball type coupling. Check for cracks, loose fasteners and wear. Regularly apply a coating of grease to the hitch contact areas of the coupling to prevent accelerated wear.

The fasteners for the coupling are very important and deserve careful attention. Replace the bolts if they are damaged in any way, and replace the locknuts if worn. Using a torque wrench, torque the fasteners to value shown on the decal near the coupling on the trailer tongue.

Jack

As necessary, grease the jack lead screw using the following procedure:

1. Fully extend the jack and apply grease to the lead screw through the grease port (hole) in the side of the jack body.
2. Cycle the jack up and down several times to distribute the grease on the screw.

The following three sub-sections pertain to trailers with tilt decks-

Cushion Cylinder

The fluid in the cylinder should be changed if the cylinder has leaked or if the deck action has become jerky and/or sluggish. Fully collapse the cylinder, and then remove the filler plug and drain out the old fluid. Add 10W hydraulic fluid until the cylinder is full and all the air has been expelled.

Deck Latch

If the latch becomes difficult to operate apply some penetrating lubricant to the moving parts. Should the deck develop a rattle, adjust the hook receiver assembly on the tilt deck.

Deck Hinge Assembly

The hinge assembly is highly stressed during loading and unloading, and so check it for cracked welds frequently.

Every six months, or sooner if service dictates, grease the deck hinges. Apply grease to the fittings (one per side) until fresh grease becomes visible.

8012DT

2.3 Running Gear

Suspension

The suspension on your trailer is either a rubber torsion axle type or the slipper leaf spring type. Rubber torsion suspensions require no maintenance.

Slipper springs have an eye formed in one end of the spring only with the other end formed into a reverse curve. The attachment of these springs is as follows:

1. The front eye is attached directly into the front hanger with a bolt and nut.

2. The rear end of the spring is captured in the rear hanger or equalizer with a 'keeper bolt' that prevents the spring from coming out when the trailer is jacked up for service.

Visually inspect the suspension system every 6,000 miles for signs of excess wear, elongation of bolt holes, and loosening of fasteners. Whenever loose or replaced the fasteners in your suspension system should be torqued as detailed below:

1. U-bolt- 45 to 60 lbs.-ft.

2. Shoulder Type shackle bolt- 30 to 50 lbs.-ft.

3. Fasteners with castle nuts- snug fit only. The cotter pin will retain the nut-bolt assembly.

Hubs and Drums

Hub Removal- Whenever the hub equipment on your trailer must be removed for inspection or maintenance the following procedure should be utilized:

1. Before jacking up the wheel, break loose the wheel lug nuts. Do not loosen them more than $\frac{1}{2}$ turn while the trailer wheel is still on the ground.

2. Jack up the wheel. Use a jack stand to support the axle. If the wheel does not rotate freely, back off the brake adjustment. Remove the wheel.

3. Remove the grease cap (hubcap) by carefully prying progressively around the flange of the cap.

4. Remove the cotter pin from the spindle nut.
5. Unscrew the spindle nut and remove the spindle washer.
6. Remove the hub from the spindle, being careful not to allow the outer bearing cone to fall out. The inner bearing cone should be retained by the grease seal.

Brake Drum Inspection

The critical surface of the brake drum is the contact area for the brake shoes during stopping. Check for excessive wear or heavy scoring. If the drum is scored or out of round, it should be machined. For a 12" brake drum, the inside diameter must be no greater than 12.090" after machining.

Bearing Inspection

Wash all grease and oil from the bearing cone using a suitable solvent. Dry the bearing with compressed air or a lint-free cloth and inspect each roller completely. Also clean and inspect the cups (races) inside the hub. Any pitting, spalling, bluing (heat damage) or corrosion is cause for replacement.

NOTE: Bearings must always be replaced in sets of a cone and cup.



RISK OF PERSONAL INJURY!

Be sure to wear safety glasses when performing the following procedure. Failure to do so can result in serious injury.

To remove the bearing cup from the hub, proceed as follows:

1. Place the hub on a flat work surface with the cup to be removed on the bottom side.
2. Using a brass drift punch, carefully tap around the small diameter end of the cup to drive it out.
3. After cleaning the hub bore area, tap in the new cup with the brass drift. Work gently around the perimeter of the cup so as not to distort it. Make sure that it is fully seated against the retaining shoulder in the hub.

8012DT

Standard Bearing Lubrication

Bearings should be lubricated every 12 months or 12,000 miles. If the axles have been submerged, the bearings should be repacked immediately. Service the bearings with lithium grease meeting NLGI No. 2 standards. Use this procedure:

1. Place a quantity of grease into the palm of your hand.
2. Press a section of the wide end of the bearing into the outer edge of the grease pile closest to the thumb, forcing grease into the interior of the bearing.
3. Repeat this while rotating the bearing from roller to roller.
4. Continue this process until you have the entire bearing completely filled with grease.
5. Before reinstalling the bearing in the hub, apply a light coat of grease on the bearing cup.

E-Z Lube Bearing Lubrication

If your axles are equipped with the E-Z Lube feature, the bearing can be lubricated without removing the hubs from the axle. The feature consists of axle spindles that have been specially drilled and fitted with a grease zerk in their ends. When grease is pumped into the zerk, it is channeled to the inner bearing and then flows back to the outer bearings and eventually back out to the grease cap hole. Regrease using this procedure:

1. Remove the rubber plug from the end of the grease cap.
2. Place a standard grease gun onto the grease zerk located in the end of the spindle. Make sure the grease gun nozzle is fully engaged on the fitting.
3. Pump grease into the zerk. The old, displaced grease will begin to flow back out the cap around the grease gun nozzle.
4. When the new, clean grease is observed, remove the grease gun, wipe off any excess, and replace the rubber plug in the cap.
5. Rotate the hub or drum by hand while adding grease.

Note: The E-Z Lube feature is designed to allow immersion. If the hubs are removed from the axle, it is imperative that the grease seals be replaced. A worn or defective grease seal will allow brake lining contamination during the bearing greasing procedure.

Seal Inspection and Replacement

Whenever the hub is removed, inspect the seal to assure that it is not nicked or torn and is still capable of properly sealing the bearing cavity. If there is any question of its condition, replace the seal. To replace the seal take the following steps:

1. Pry the old seal out of the hub with a screwdriver. Be careful not to scratch or nick the sealing surface of the hub with the end of the screwdriver.
2. Clean the hub surfaces. If the bearing is removed for any reason, be sure to reinstall it before pressing in the new seal. Apply a Permatex sealant to the outside of the new seal (metal seal shells only).
3. Tap the seal into place using a clean wood block.

Hub Reinstallation and Bearing Adjustment

1. Place the hub (with inner bearing set and grease seal installed), outer bearing, spindle washer and spindle nut back on the spindle in the reverse order of removal. Rotate the hub assembly while tightening the spindle nut to approximately 50 lbs.-ft. of torque.
2. Then loosen the spindle nut to remove the torque. Do not rotate the hub.
3. Finger tighten the spindle nut until just snug.
4. Install a new cotter pin (tang washer for E-Z lube hubs). If necessary, the nut can be backed off slightly to align the castellations with the cotter pin hole in the spindle. Bend over the tangs of the pin.
5. Check that the hub turns freely and is without unusual sounds. The spindle nut should be free to move until restrained by the cotter pin or tang washer.

2.4 Wheels and Tires

Wheels

Wheels are a very important and critical component of your running gear. Inspect them visually for cracks or elongated bolt holes whenever they are removed for any reason. If it becomes necessary to replace the wheels on your trailer, be certain that the replacement units match the originals in the following regards:

1. Bolt Circle. Many bolt circle dimensions are available and some vary by so little that it might be possible to attach an improper wheel that does not match the axle hub. Be sure to match your wheel to the axle hub.
2. Capacity. Be sure your wheels have enough load carrying capacity and pressure rating to match the maximum load of the tire and trailer.
3. Offset. This refers to the relationship of the center line of the tire to the hub face of the axle. Care should be taken to match a replacement wheel with the same offset wheel as originally equipped. Failure to match offset can result in reduced carrying capacity of your axle.
4. Rim Contour.



RIM CONTOURS!

Use only the approved rim contours as shown in the Tire and Rim Yearbook or the tire manufacturers catalog. The use of other rim contours is dangerous. Failure to use the proper rim contour can result in explosive separation of the tire and wheel and could cause a serious accident.



WHEEL MODIFICATIONS!

Do not attempt to repair or modify a wheel. Even minor modifications can have a great effect. Do not install a tube to correct a leak through the rim. If the wheel is cracked, the air pressure in the tube may cause the pieces of the wheel to explode with great force and can cause serious injury or death.

When installing the wheels, make sure that the hub and wheel mating surfaces are clean and free of rust, dirt and excess paint. The studs and threads must be clean, dry and in good condition for applying installation torque.

Tighten the lug nuts in the following pattern in three steps- first to 20-25 lbs.-ft., next to 50-60 lbs.-ft., and then to the final torque of 80 to 95 lbs.-ft.

Tighten wheel nuts every 50 miles for the first 200 miles. Check periodically.

Tires

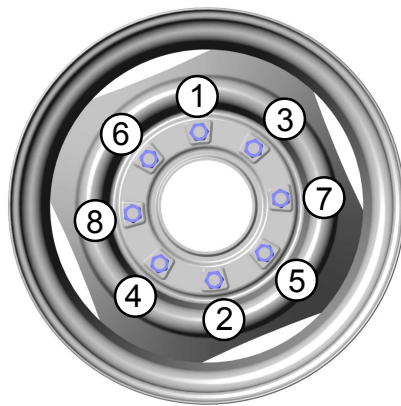

Eight bolt pattern



Six bolt pattern

8012DT

Before mounting tires onto wheels make certain that the rim size and contour is approved for the tire as shown in the Tire and Rim Association Yearbook or the tire manufacturers catalog. Also make sure the tire will carry the rated load. If the load is not equal on all tires due to trailer weight distribution, use the tire rated for the heaviest wheel position.

To determine the tire capacity for ST tires, use the capacity rating molded into the tire.

Use tire mounting procedures as outlined by the Rubber Manufacturers Association or the tire manufacturer.

Inflation Pressure

Correct inflation pressure for the ST235/80R16 tire is 65 psi and is the most important factor in tire life. Inflation pressure should be as recommended by the manufacturer for the load. Pressure should be checked cold before operation. Do not bleed air from tires when they are hot. Check inflation pressure weekly during use to insure the maximum tire life and tread wear. Use the tire wear diagnostic chart to help you pinpoint the causes and solutions of tire wear problems.

NOTE: Tire wear should be checked frequently because once a wear pattern becomes firmly established in a tire it is difficult to stop, even if the underlying cause is corrected.

Tire Wear Diagnostic Chart

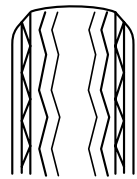
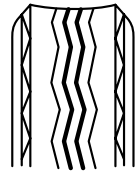
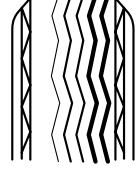
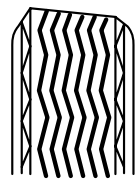
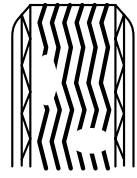
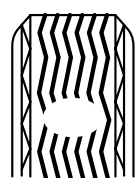
| | Wear Pattern | Cause | Corrective Action |
|---|--------------|---------------------------------|---|
|  | Center Wear | Over inflation | Adjust pressure to particular load per tire catalog |
|  | Edge Wear | Under inflation | Adjust pressure to particular load per tire catalog |
|  | Side Wear | Loss of camber or over loading | Adhere to load limits. Have axle aligned |
|  | Toe Wear | Incorrect toe-in | Have axle aligned |
|  | Cupping | Loose bearing or out of balance | Adjust bearing; balance tires |
|  | Flat spots | Wheel lockup or tire skidding | Adjust brakes; avoid sudden stops |

2.5 Electrical

Harnesses and Lights

The electrical harnesses in the trailer run within the frame members and require no maintenance. The oval stop/turn/tail lights and the round clearance lights are all of the sealed type and do not have a separately replaceable bulb. If a light stops working, first check the connection at the light for voltage (with a test lamp or volt meter) to verify that the electrical system is functioning properly. If it is then replace the lamp; if not then troubleshoot the electrical system.

Junction Block

The junction block requires no regular maintenance. If an electrical problem develops, check for corroded or loose terminals.

Electrical Plug

The plug should be kept clean and free of dirt. If an electrical problem develops, loosen the plug cover retaining screw, slide the cover down over the harness, and check the screws that hold the wires for security. Also check for stray or broken strands of wire.

2.6 Brake System (Common to Hydraulic and Electric)

CAUTION ASBESTOS DUST HAZARD!

Since some brake shoe friction materials contain asbestos, certain precautions need to be taken when servicing brakes:

- 1. Avoid creating or breathing dust.*
- 2. Avoid machining, filing or grinding the brake linings.*
- 3. Do not use compressed air or dry brushing for cleaning.
(Dust can be removed with a damp brush.)*

CAUTION RISK OF PERSONAL INJURY!

Whenever it becomes necessary to jack the trailer it is up to you to ensure that the trailer or axle is supported securely. Use blocks or jack stands on solid ground, especially if you are going to be working under the trailer.

Brake Adjustment

Brakes should be adjusted (1) after the first 200 miles of operation when the brake shoes and drums have 'seated', (2) at 3000 mile intervals, (3) and as use and performance requires. Adjust the brakes as follows:

1. Jack up the wheel to be adjusted. Support the raised wheel securely.
2. Remove the adjusting hole cover from the adjusting slot on the bottom of the brake backing plate.
3. With a screwdriver or a brake adjusting tool, rotate the starwheel of the adjuster assembly to expand the brake shoes. Adjust the brake shoes until the pressure of the linings against the drums makes the wheel very difficult to turn.
4. Now rotate the starwheel in the opposite direction until the wheel turns freely with a slight lining drag.

5. Replace the adjusting hole cover and lower the wheel to the ground.
6. Repeat the above procedure on all brakes.

Brake Cleaning and Inspection

Your trailer brakes must be inspected and serviced at yearly intervals or more often as use and performance requires. Use the following guidelines for inspection:

Wheel Cylinders- Inspect for leaks and smooth operation. Clean with brake cleaner and flush with fresh brake fluid. Hone or replace as necessary.

Magnets and Magnet Arms- Inspect magnets for wear. Inspect magnet arms for loose or worn parts.

Shoes and Linings- Inspect visually. Replace if the lining is worn to $1/16$ " thickness or less, contaminated with grease or brake fluid, or abnormally scored or gouged.

Hardware- Check all hardware. Check shoe return spring, hold down springs, and adjuster springs for stretch or wear. Replace as required. Service kits are available.

Drums- Check drums for scoring, cracking, or uneven wear. Machine drum surface only if under maximum diameter. Replace as necessary. See page 17 for more information.

Brake Lubrication

Moving brake components should get a light film of high temperature grease or anti-seize compound. These areas include the brake anchor pin, the actuating arm bushing and pin, and the areas on the backing plate that are in contact with the brake shoes and actuating lever arm.

CAUTION BRAKE LINING CONTAMINATION!

Do not get grease or oil on the brake linings, drums, or magnets.

2.7 Hydraulic Brake System

Operation

The hydraulic brakes on your trailer are much like those on your car. The hydraulic brake fluid from a master cylinder is used to actuate the wheel cylinder which, in turn, applies force against the brake shoes and drum. The main difference between automotive hydraulic brakes and hydraulic trailer brakes is the actuation system which transfer the braking signal from the tow vehicle to the brakes.

The surge braking system uses a specially designed trailer hitch coupler which has a hydraulic cylinder built in. When the tow vehicle applies its brakes, the tow vehicle decelerates causing the trailer to apply a pushing force against the hitch. This force actuates the surge hitch hydraulic cylinder, forcing brake fluid under pressure into the wheel cylinders, which then causes the trailer brakes to be applied.

Surge Actuator Maintenance

Before towing check that the brake fluid reservoir is full. If not, refill to $\frac{3}{8}$ inch below the top of the reservoir with DOT 3 brake fluid. Check for leaks and repair as required.

A film of grease on the coupler will extend coupler life while eliminating squeaking. Wipe clean and renew film each time trailer is used.

Before towing, examine the actuator for bent parts or excessive wear. Replace parts as necessary. Check to determine that mounting bolts are tight and welds not cracked.

Some earlier models used the Dico actuator that had grease fittings for the internal rollers. If your trailer is equipped with this actuator, grease the rollers every 90 days or 5000 miles.

Excessive actuator travel (over one inch) when brakes are applied indicates a need to adjust the brakes. Adjust per instructions found in the brake section of this manual. In general, back-off adjusters 10 clicks from locked rotation. Adjust Free-Backing brakes by rotating in forward direction only.

Corrosive Environment Warning



CORROSIVE ENVIRONMENTS!

Saltwater, granular fertilizers and other corrosive materials are destructive to metal. To prolong the life of a braking system used under corrosive conditions the actuator should be flushed after use with a high pressure water hose. Failure to properly clean the actuator could weaken it and/or cause it to fail and result in serious injury and/or property damage.

Hydraulic Lines

Occasionally check the condition and security of the lines and hoses that comprise the brake hydraulic system. Check that the lock tabs and clamps are in place and securely holding the lines to the frame. Look for signs of leakage, especially if you have had to add fluid to the reservoir frequently.

Check the tubing for kinks, cracks, blockage and corrosion, and replace any that are questionable. Inspect the hoses for age checking (cracking of the outer rubber sheath), damage, blisters, or other signs of impending failure and replace as necessary.

Hydraulic Brakes

The hydraulic brakes on your trailer use a single piston wheel cylinder to apply the brakes. A description of operation of this brake is as follows:

When the brakes are applied, the single-acting wheel cylinder moves the primary shoe towards the drum. The frictional force between the brake drum and the lining attempts to turn the primary shoe into the secondary shoe through the adjuster link assembly. The secondary shoe is forced into the anchor pin and from this point, the secondary and primary shoes attempt to 'wrap around'. In essence, the brake has utilized frictional force to augment the hydraulic actuation force on the primary shoe.

These brakes incorporate a 'free-backing' design which allows a surge actuator equipped trailer to move easily in reverse. Without this feature the surge actuator would be applying the trailer brakes as the tow vehicle is attempting to back the trailer.

Brake System Bleeding

The preferred method for bleeding air out of the brake hydraulic system is to use a pressure-type brake bleeder. Follow the manufacturers directions for using the bleeder.

To bleed the brakes manually, proceed as follows:

1. Fill the master cylinder in the surge actuator with fresh DOT 3 brake fluid. Remove the two $\frac{5}{16}$ " hex head bolts that hold the lever guides and emergency lever spring. Remove the lever guide and emergency lever spring. Using short strokes, pull forward on emergency lever until all bubbling stops inside the master cylinder.

2. Install a bleeder hose on the bleeder screw of the left wheel cylinder (left rear if tandem axle). You should always begin the bleeding operation on the wheel cylinder that is farthest from the master cylinder. Have the loose end of the hose submerged in a glass container of brake fluid so that you can observe bubbling.

3. Loosen the bleeder screw one turn and operate the breakaway lever slowly until all bubbling stops. Close the bleeder screw securely.

4. Check the fluid level in the master cylinder reservoir and replenish as necessary between wheel cylinder bleedings.

5. Using the same procedure move to the right brake (or right rear if tandem) and bleed it; for tandem trailers then bleed the left front brake next, and finish with the right front brake.

6. Fill the reservoir to within $\frac{3}{8}$ " below the top and replace filler cap securely. Reinstall the lever guides and emergency spring with the two bolts that were removed earlier.

8012DT

Hydraulic Brake System Troubleshooting Chart

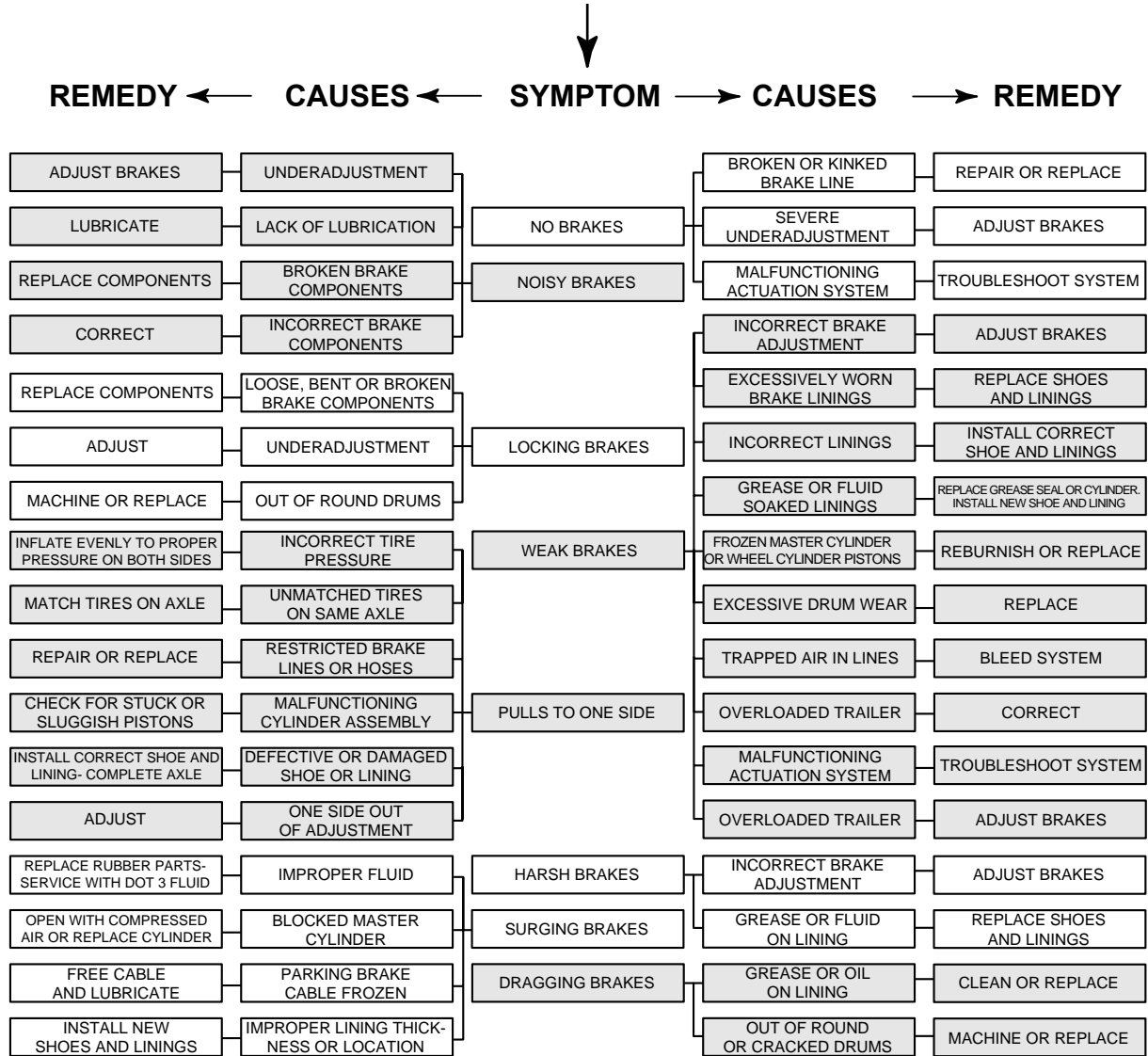

2.8 Electric Brake System

Operation

The electric brakes on your trailer are similar to the drums brakes on your automobile. The basic difference is that your automotive brakes are actuated by hydraulic pressure while the electric brakes are actuated by an electromagnet. With all of the brake components connected into the system, the brake will operate as follows:

1. When the electrical current is fed into the system by the controller, it flows through the electromagnets in the brakes. The high capacity electromagnets are energized and are attracted to the rotating armature surface of the drums which moves the actuating levers in the direction that the drums are turning.

2. The resulting force causes the actuating cam block at the shoe end of the lever to push the primary shoe out against the inside surface of the brake drum. The force generated by the primary shoe acting through the adjuster link then moves the secondary shoe out into contact with the brake drum.

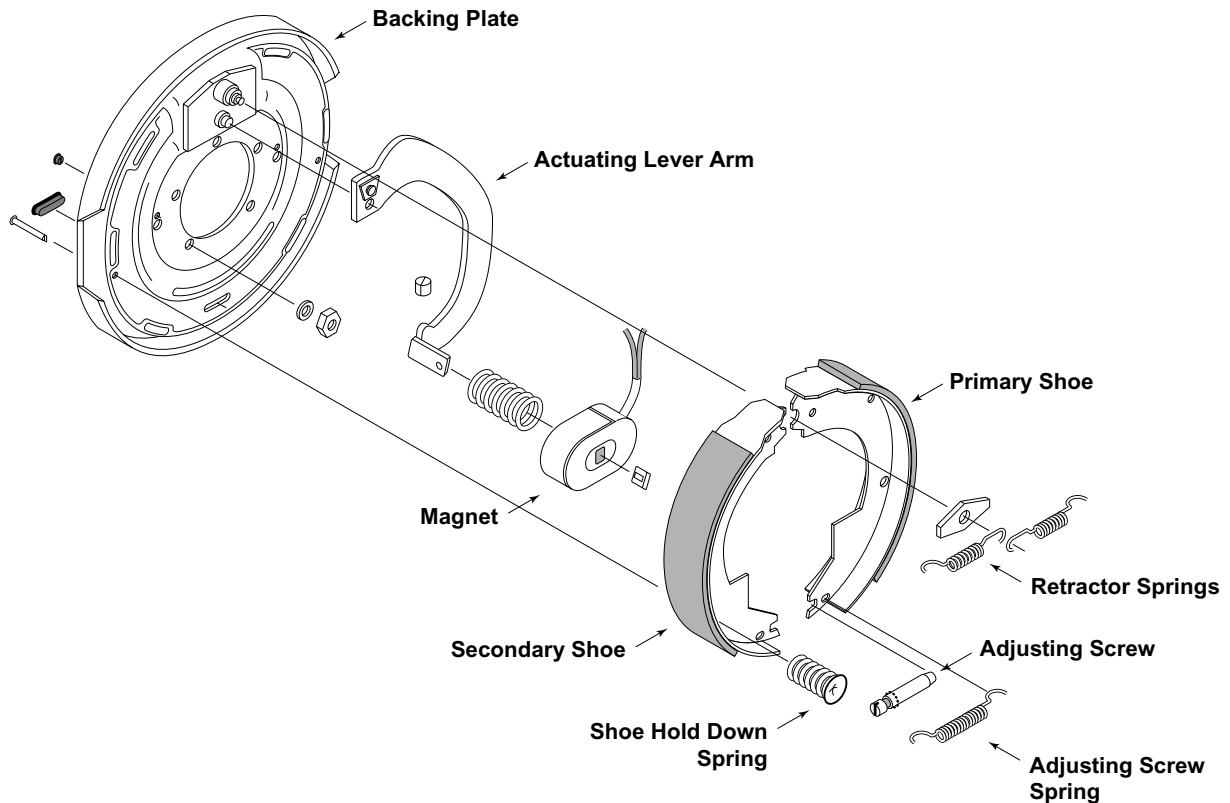

Increasing the current flow to the electromagnet causes the magnet to grip the armature surface of the brake drum more firmly. This results in increasing the pressure against the shoes and brake drums until the desired stop is accomplished.

Using your Brakes Properly

Your trailer brakes are designed to work in synchronization with your tow vehicle brakes. Never use your tow vehicle or trailer brakes alone to stop the combined load.

In order for your tow vehicle to provide the correct amperage flow to the trailer brake magnets for comfortable and safe braking it is imperative that you make the proper brake system adjustments. Changing trailer load and driving conditions as well as uneven alternator and battery output can mean unstable current flow to the brake magnets. It is therefore crucial that you maintain and adjust your brakes as set forth in this manual, use a properly modulated brake controller, and perform the synchronization procedure noted below.

In addition to the synchronization adjustment detailed below, electric brake controllers provide a modulation function that varies the current to the electric brakes with the pressure on the brake pedal or amount of deceleration of the tow vehicle. It is important that your brake controller provide approximately 2 volts to the braking system when the pedal is first depressed and gradually increases the voltage to 12 volts as brake pressure is increased. If the controller “jumps” immediately to a high voltage output, even during a gradual stop, then the electric brakes will always be fully energized and will result in harsh brakes and potential wheel lockup.

Proper synchronization of the tow vehicle to trailer braking can only be accomplished by road testing. Brake lockup, grabbiness, or harshness is quite often due to the lack of synchronization between the tow vehicle and the trailer being towed, too high of a threshold voltage (over 2 volts), or under adjusted brakes.

Before any synchronization adjustments are made, your trailer brakes should be burnished-in by applying the brakes 20 to 30 times with approximately a 20 mph decrease in speed, for example slowing from 40 to 20 mph each time. Allow ample time for the brakes to cool between application. This allows the brake shoes and magnets to slightly “wear-in” to the drum surfaces.

Synchronization

To insure safe braking performance and synchronization, *read the brake controller manufacturer's instructions completely before attempting any synchronization procedure.*



Before making road tests, make sure that the area is clear of vehicular and pedestrian traffic. The purpose of these tests is to adjust the brakes for safe operation, and therefore you should expect that initial braking action may be weak or irregular.

Make several hard stops from 20 mph on a dry paved road free of sand and gravel. If the trailer brakes lock and slide, decrease the gain setting on the controller. If they do not slide, slightly increase the gain setting. Adjust the controller just to the point of impending brake lockup and wheel skid.

Note: Minimum vehicle stopping distances are achieved when wheels approach lockup, however actual brake lockup should be avoided as it results in poor vehicle stability and control. Depending on load, brake type, wheels and tires, not all trailer brakes are capable of wheel lockup.

If the controller is applying the trailer brakes before the tow vehicle brakes, then the controller level adjustment should be adjusted so that the trailer brakes come on in synchronization with the tow vehicle brakes. For proper braking performance, it is recommended that the controller be adjusted to allow the trailer brakes to come on just slightly ahead of the tow vehicle brakes. When proper synchronization is achieved there will be no sensation of the trailer “jerking” or “pushing” the tow vehicle during braking.

Controllers

Start by making sure trailer brakes are properly adjusted. Some controllers have a gain control to vary the amount of current to the brakes, and a level control which sets the controller's inertia sensor to sense deceleration. The level adjustment also can be used to vary when the trailer braking is felt. The gain or output control adjustment usually controls the maximum amount of amperage available to the brakes. This can be adjusted for varying trailer loads. The chart below details adjustments available for different brake controllers.

8012DT



CONTROLLER PARAMETERS!

Do not adjust the brake controller outside the parameters outlined by the controller manufacturer's instructions.

| Controller* | Brake Timing Adjustment | Brake Force Adjustment |
|-----------------------------|-------------------------|------------------------|
| Tekonsha (9010,20,30,55) | Level | Gain |
| Kelsey 81741A | Level | Gain |
| Draw-Tite 5100 | Sync | Output |

*See manufacturer's instructions

Magnets

Your electric brakes are equipped with high quality electromagnets that are designed to provide the proper input force and friction characteristics. Your magnets should be inspected and replaced if worn unevenly or abnormally. As indicated below a straight-edge should be used to check wear.

Even if wear is normal as indicated by your straightedge, the magnets should be replaced if any part of the magnet coil has become visible through the friction material facing of the magnet. It is also recommended that the drum armature surface be refaced when replacing magnets. Magnets should also be replaced in pairs (both sides of the axle). Use only genuine Dexter replacement parts when replacing your magnets.

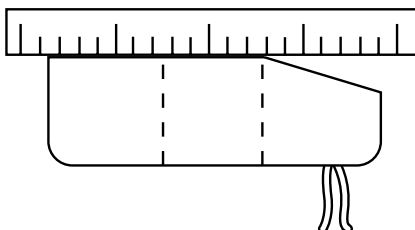

Abnormal Wear
(Replace Magnet)

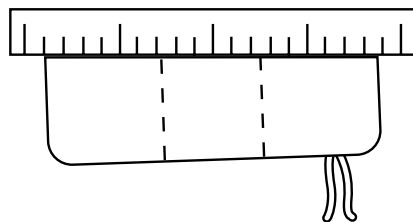

Normal Wear

Electric Brake System Troubleshooting

Most electric brake system malfunctions that cannot be corrected by either brake adjustments or synchronization adjustments can generally be traced to electrical system failure. Mechanical causes are ordinarily obvious, i.e. bent or broken parts, worn out linings or magnets, seized lever arms or shoes, scored drums, loose parts, etc. A voltmeter and ammeter are essential tools for proper troubleshooting of electric brakes.

Measuring Voltage

System voltage is measured at the magnets by connecting the voltmeter between the two magnet lead wires at any brake. This may be accomplished by using a pin probe inserted through the insulation of the wires leading from the trailer frame to the brake assembly, or if necessary by cutting the wires. The engine of the tow vehicle should be running when checking the voltage so that a low battery will not affect the readings.

Voltage in the system should begin at zero volts and as the controller bar is slowly actuated should increase gradually to about 12 volts. This gradual increase of voltage is referred to as modulation. No modulation means that when the controller begins to apply voltage to the brakes it applies an immediate high voltage (acting more like an On-Off switch), which causes the brakes to apply instantaneous maximum power.

The threshold voltage of a controller is the voltage that is applied to the brakes when the controller first energizes. The lower the threshold the smoother the brakes will operate. Too high a threshold voltage (in excess of 2 volts as quite often found in heavy duty controllers) can cause grabby, harsh brakes.

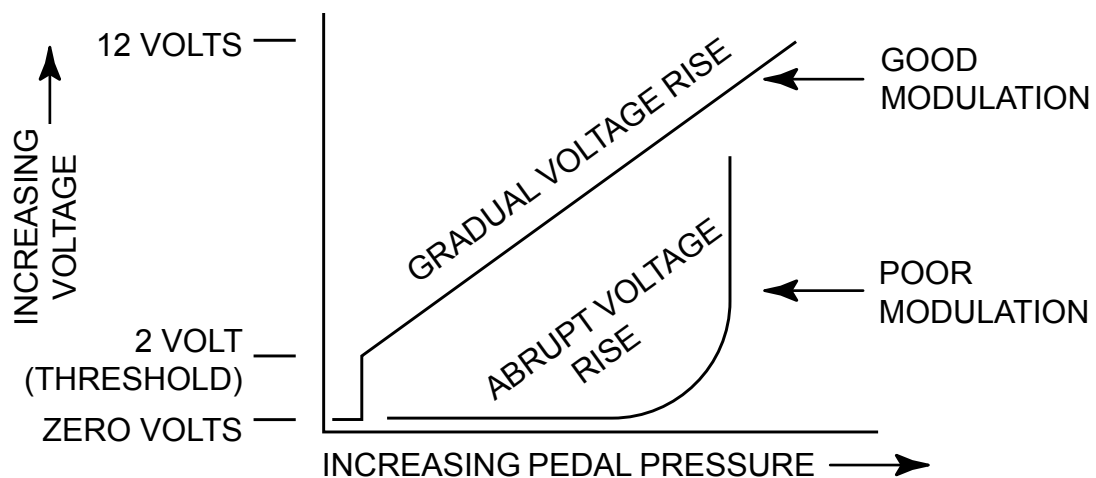

8012DT

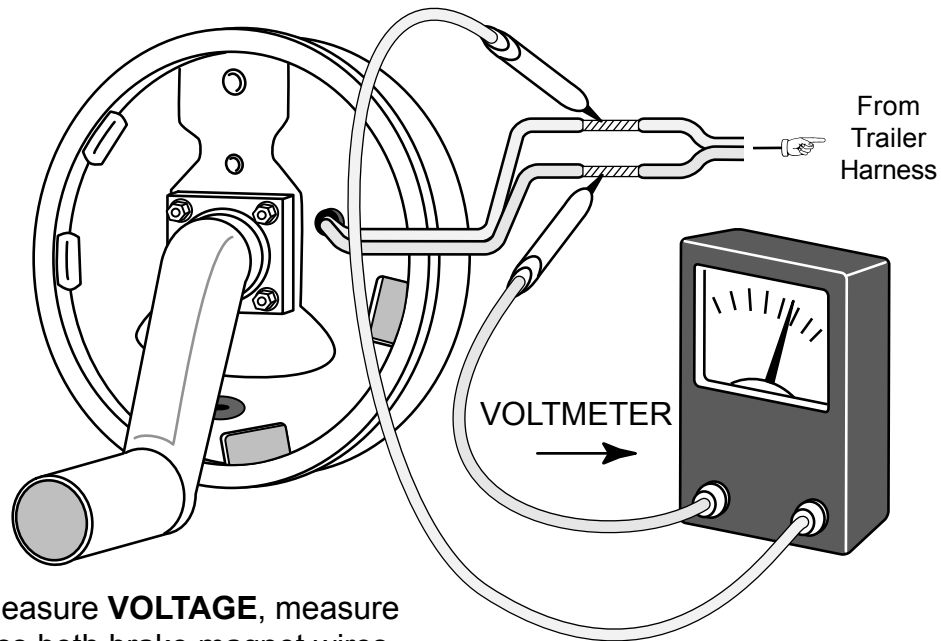

To measure **VOLTAGE**, measure across both brake magnet wires.

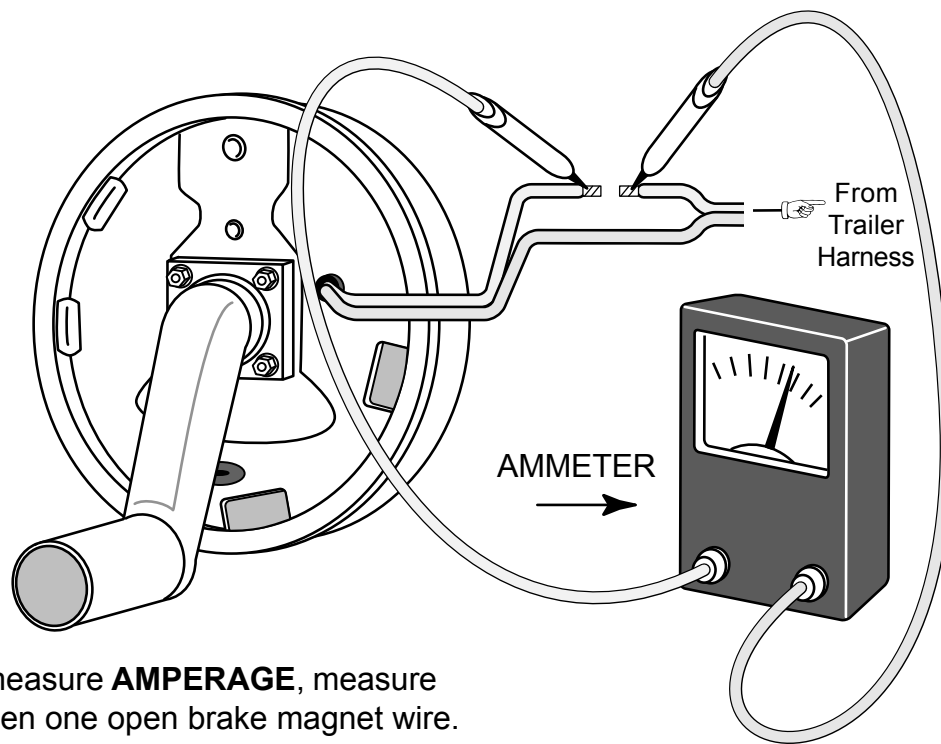

To measure **AMPERAGE**, measure between one open brake magnet wire.

Measuring Amperage

System amperage is the amperage being drawn by all the brakes on the trailer. The engine of the tow vehicle should be running when checking the amperage.

One place to measure system amperage is at the BLUE wire of the controller which is the output to the brakes. The BLUE wire must be disconnected and the ammeter put in series into the line. System amperage draw should be as noted in the paragraph below. Make sure your ammeter has sufficient capacity and be sure to connect it with the correct polarity to avoid damaging the meter.

If a resistor is used in the brake system it must be set at zero or bypassed completely to obtain the maximum amperage reading.

Individual brake amperage draw can be measured by inserting the ammeter in the line at the magnet you want to check. Disconnect one of the magnet lead wires and attach the ammeter between the two ends. Make sure that the wires are properly reconnected and sealed after testing is complete.

By far the most common electrical problem is low or no voltage and amperage at the brakes. Common causes of this condition are:

1. Poor electrical connections.
2. Open circuits.
3. Insufficient wire size.
4. Broken wires.
5. Blown fuses (fusing of brake circuits is not recommended).
6. Improperly functioning controllers or resistors.

Another common electrical problem is partially shorted circuits (indicated by abnormally high system amperage). These are occasionally the most difficult to find. Possible causes are:

1. Shorted magnet coils.
2. Defective controllers.
3. Bare wires contacting a grounded object.

8012DT

Finding a system short is a matter of isolation. If the high amperage reading drops to zero by unplugging the trailer, the short is in the trailer. If the amperage reading remains high with all the brake magnets disconnected, the short is in the trailer wiring.

All electrical troubleshooting procedures should start at the controller. Most complaints regarding brake harshness or malfunction are traceable to improperly adjusted or non-functioning controllers. See your controller manufacturers data for proper adjustment and testing procedures. If the voltage and amperage is not satisfactory, proceed to the connector and then to the individual magnets to isolate the problem source. 12 volts output at the controller should equate to 10.5 volts minimum at each magnet. Nominal system amperage at 12 volts with the magnets at normal operating temperature, i.e. not cold, system resistor at zero and controller at maximum gain should be 3.0 amps for each magnet in the circuit.

Electric Brake System Troubleshooting Chart

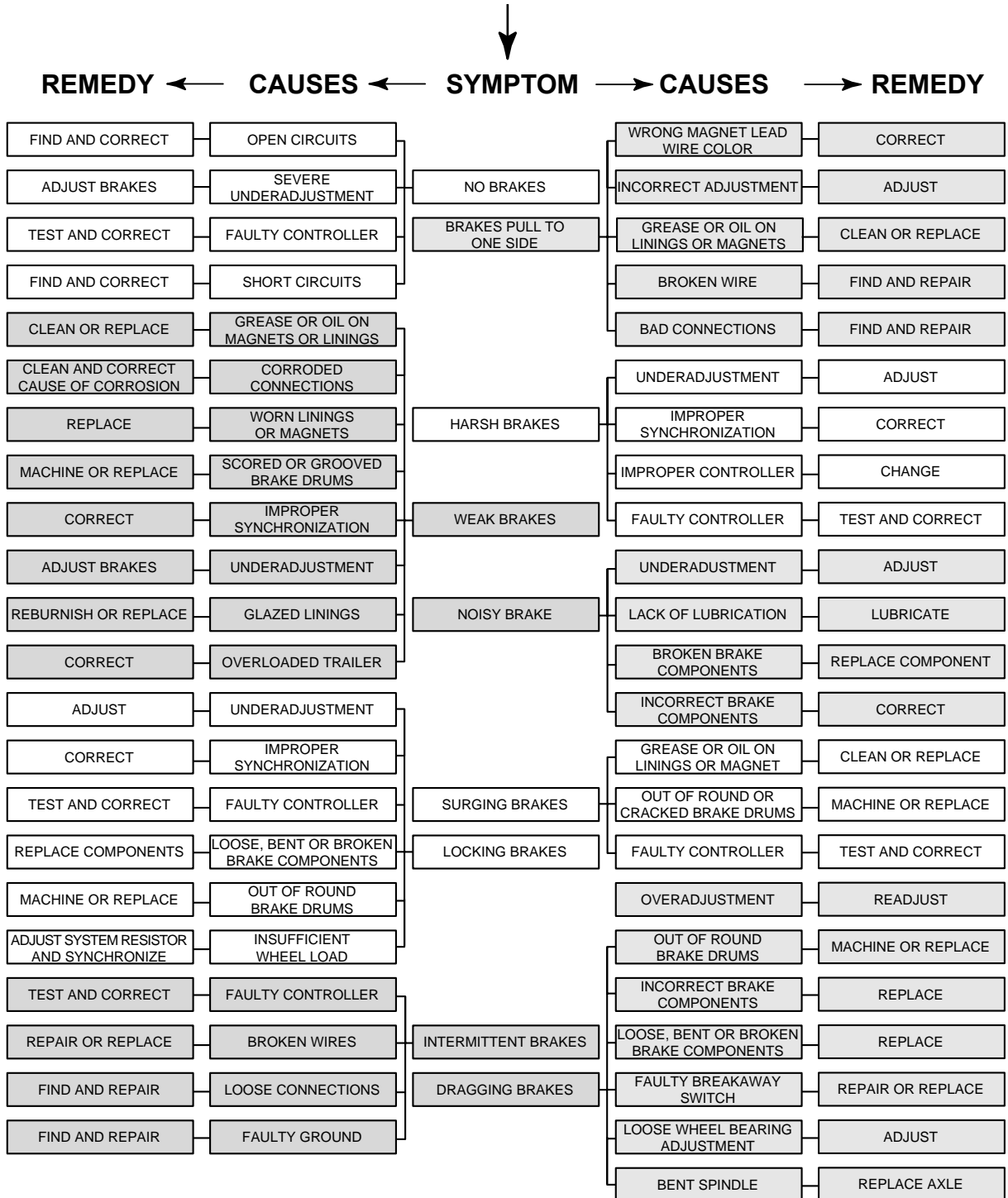

2.9 Pre-Storage Maintenance

If your trailer is to be stored for an extended period of time or over the winter, it is important that the trailer be prepared properly.

1. Give the trailer a thorough wash down and let it dry completely.
2. Remove the breakaway battery (for electric brake systems) and store inside, out of the weather. Charge the battery at least every 90 days.
3. Jack up the trailer and place jack stands or blocks under the suspension tie plates so that the weight will be off the tires. The best way to jack the trailer for this is to place the jack under the trailer frame rail using a wood block to protect the finish. Raise the jack until the suspension assembly on that side is high enough to insert the blocks. Never jack or support the trailer using the axle tube or equalizers.
4. Lubricate exposed mechanical moving components such as the hitch and suspension parts. Store the trailer under cover for best protection, or under a tarp if cover is not available. Leaving the trailer out in the weather may cause accelerated aging.
5. No wheel bearing service is necessary at this time unless the axles have been immersed.

2.10 Pre-Season Maintenance

Before removing the trailer from the jack stands:

1. Remove all wheels and hubs (brake drums). Note which spindles the drums were removed from so that they can be reinstalled in the same location.
2. Inspect the suspension for wear and corrosion and correct any discrepancies.
3. For leaf spring suspensions, check the tightness of all the hanger bolts, shackle bolts, and U-bolt nuts per recommended torque values (see page 16).
4. Check all brake linings, brake drums and armature faces for excessive wear or scoring.
5. Check brake magnets with an ohmmeter. The magnets should check at 3.2 ohms. If shorted or excessively worn, replace the magnets.
6. Lubricate all brake moving parts.



BRAKE LINING CONTAMINATION!

Do not get grease or oil on brake linings or magnet face.

7. Remove any rust from braking surface and armature surface with fine emery paper or crocus cloth. Protect the bearings from contamination while so doing.
8. Remove and re-pack the wheel bearings (see page 18). Install new grease seals when the bearings are reinstalled.
9. Reinstall the hubs and adjust bearings as outlined on page 19.
10. Remount and torque the wheel lug nuts. Be sure to remember to re-torque the lugs periodically (see page 21).
11. Check cold tire inflation pressures- ST235/80R16, 65 psi.

8012DT

Section 3. Parts

3.1 Structural Components

| Ref. | Quantity | Description | Part No. |
|------|----------|---|-----------------------|
| 1. | 1 | Sub Frame | SA-12934 |
| 2. | 1 | Dump Body | SA-12955 |
| 3. | 1 | 3-Way Tailgate Assembly | SA-13849 |
| 4. | 2 | Ramp Assembly | SA-14056 |
| 5. | 2 | Safety Chain and Hook Assembly | 1/4" ASSY |
| 6. | 4 | D-ring | B38W |
| | 1 | Tandem Hanger Kit | H202/AP216 PKG2 10429 |
| 7. | 2 | Front Hanger | 28-1 |
| 8. | 2 | Equalizer | 13-44 |
| 9. | 2 | Equalizer Bolt, 7/8" x 4-5/8" | 7-1-1 |
| 10. | 2 | 7/8" Hex Locknut for 7-1-1 bolt | 6-111 |
| 11. | 2 | Center Hanger | 29-1 |
| 12. | 4 | 9/16" -18 x 3-1/4" Shackle Bolt | 91635B |
| 13. | 4 | 9/16" -18 Hex Locknut | 916DLN |
| 14. | 2 | Rear Hanger | 30-1 |
| 15. | 4 | 5/16" -18 x 3-1/4" Spring Retainer Bolt | 7-7 |
| 16. | 4 | 5/16" -18 Hex Locknut | 6-11 |

8012DT

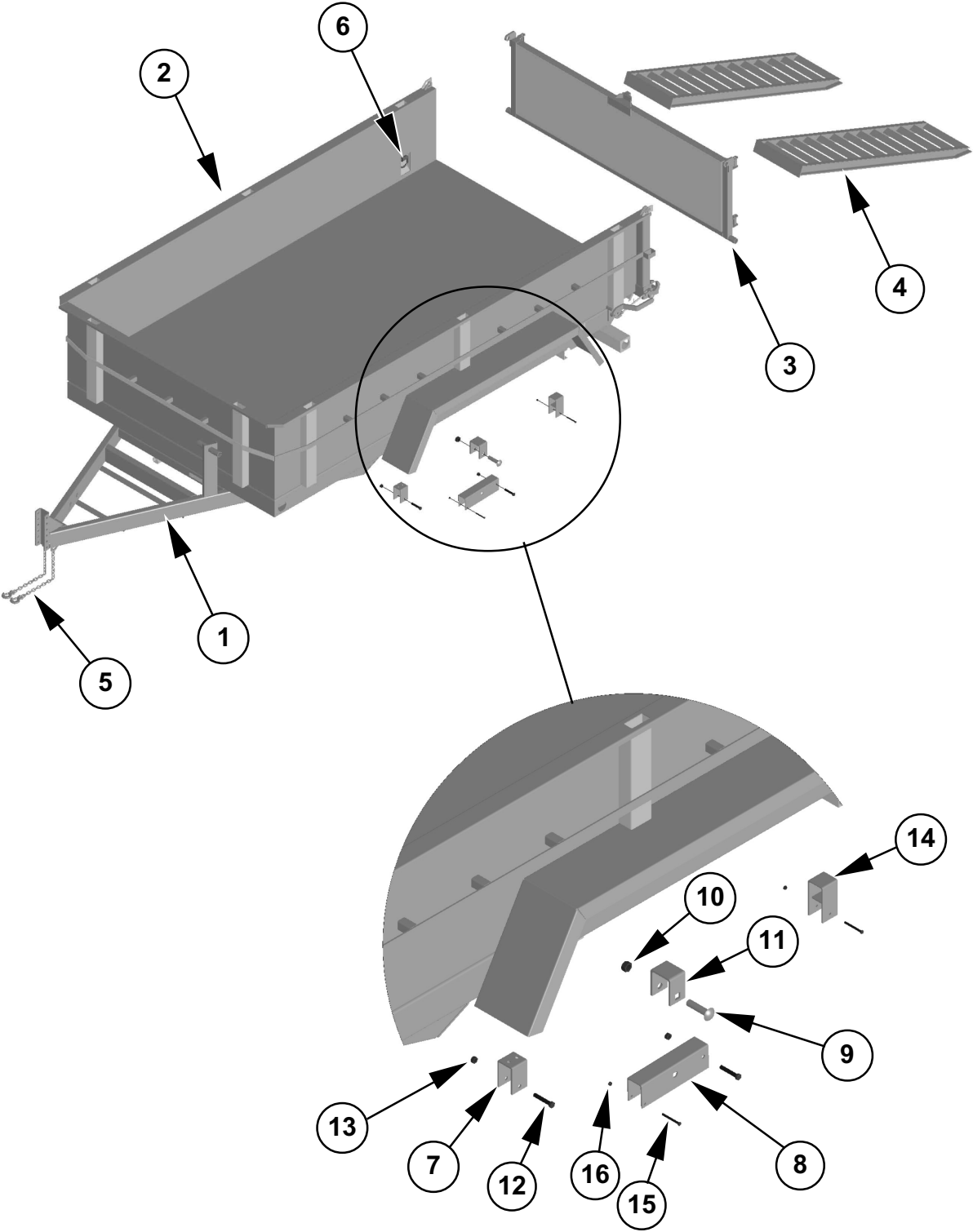

THIS PAGE LEFT BLANK INTENTIONALLY

3.2 Major Sub-Assemblies

Binkley Jack

| Ref. | Quantity | Description | Part No. |
|------|----------|---|-----------------|
| | 1 | Dump Trailer Jack Assembly | SA-14093 |
| 1. | 1 | Binkley Jack Drop Leg 12K | 4800 |
| 2. | 1 | Jack Drop Foot Extension | C-14059 |
| 3. | 1 | Jack Plunger Extension | C-14058 |
| 4. | 1 | Jack Handle Extension | SA-14142 |
| 5. | 1 | Universal Crank | 297600 |
| 6. | 1 | Jack Handle Hook | C-04501 |

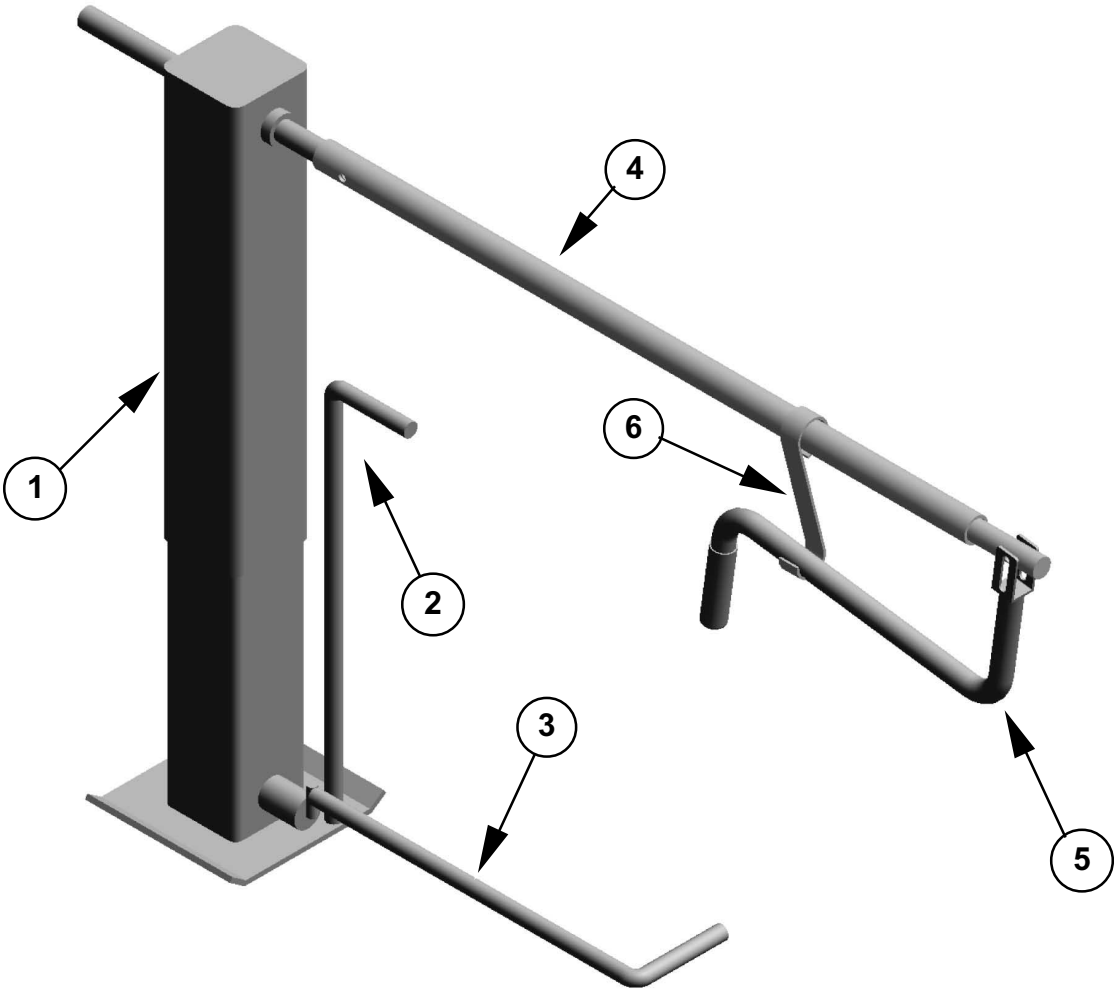

PARTS

8012DT

Couplers

| Ref. | Quantity | Description..... | Part No. |
|------|----------|---|----------|
| 1. | 1 | 2-5/16" Lever Lock Coupler | 07678-97 |
| 2. | 4 | 5/8" -11 UNC x 1-5/8" Hex Head Bolt Grade 5 | 04051 |
| 3. | 4 | 5/8" -11 UNC Stover Lock Nut | 03730 |

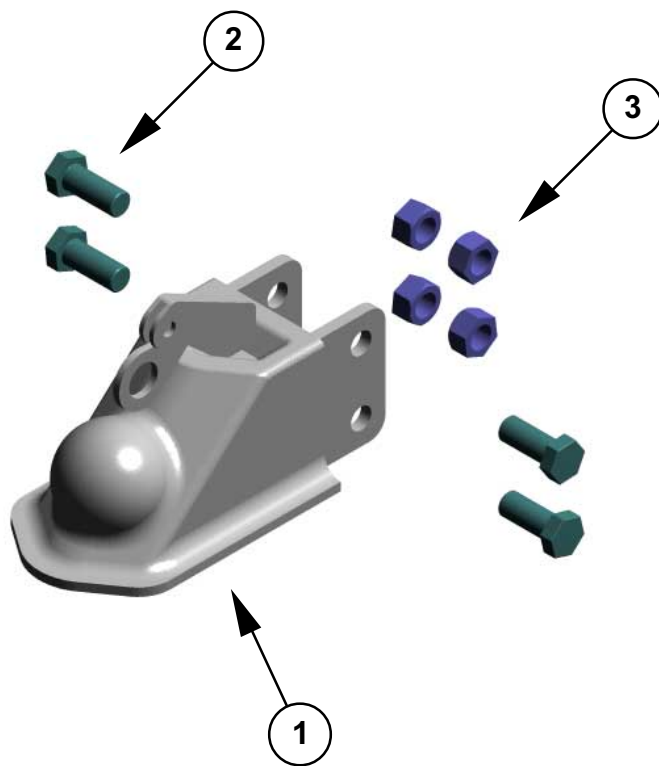

8012DT

| Ref. | Quantity | Description | Part No. |
|------|----------|--|----------|
| 1. | 1 | Pintle Eye | 09557-97 |
| 2. | 2 | 5/8"-11 UNC x 4-1/2" Hex Head Bolt Grade 5 | 02434 |
| 3. | 2 | 5/8"-11 UNC Nylon Insert Lock Nut | 02587 |

Note: Pintle Eye and associated hardware is an available option.

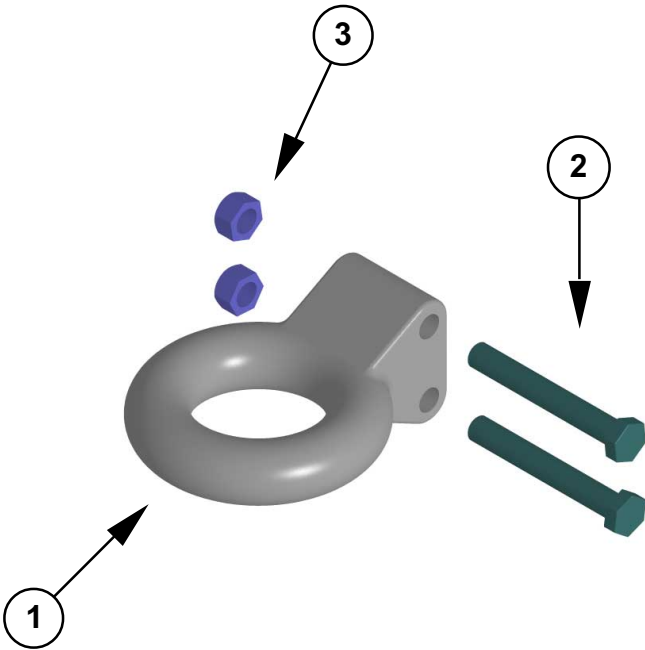

PARTS

8012DT

3.3 Running Gear

| Ref. | Quantity | Description | Part No. |
|------|----------|---|--------------|
| 1. | 2 | Axle Assembly (hydraulic brakes) | 70865HFBSTEZ |
| . | 2 | Axle Assembly (electric brakes) | 70865ESTEZ |

Note: Axle assemblies include brakes, drums, slipper springs and u-bolt kits.

| | | | |
|----|---|---|-----------|
| 2. | 4 | 24" 3.5K Slipper Spring | 1203T3 |
| | 4 | U-Bolt Kit (3" round axle) | APUBR-8 |
| 3. | 2 | U-bolt, 1/2" | 1755892LN |
| 4. | 1 | Tie Plate | 117521 |
| 5. | 4 | Hex Nut, 1/2" | 12N |
| 6. | 4 | Lock Washer, 1/2" | 12LW |

Note: Kit names are **bold type** while component names are regular type; kit components, if itemized, are indexed under the kit name. Kit component quantities are per kit; other parts and kit quantities are per trailer.

8012DT

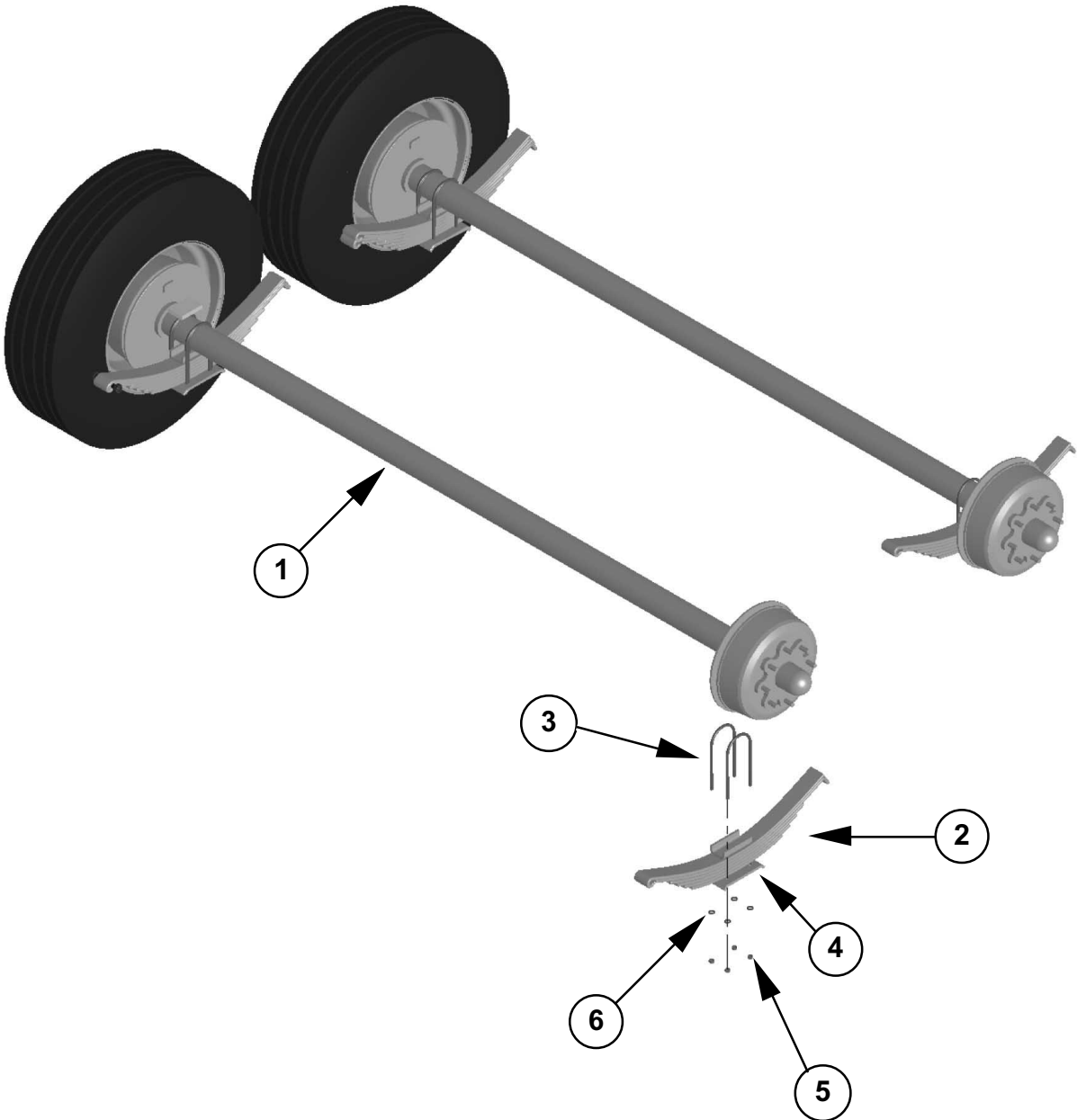

PARTS

8012DT

Hydraulic Brake Components

| Ref. | Quantity | Description | Part No. |
|------|----------|---|------------|
| | 1 | Complete Brake Assembly- Right | SB42028 |
| | 1 | Complete Brake Assembly- Left | SB42029 |
| 1. | 1 | Back Plate Assembly | SB18496-30 |
| 2. | 1 | Brake Shoe Kit (2 Front & 2 Rear) | SB18498 |
| 3. | 1 | Bleeder | 05431 |
| 4. | 1 | Wheel Cyl. Assy-Right | SB9776 |
| 4. | 1 | Wheel Cyl. Assy-Left | SB9777 |
| 5. | 3 | 5/16-18 UNC x 5/8" Hex Bolt | 05961 |
| 6. | 1 | Push Rod | SB9783 |
| 7. | 1 | Adjusting Screw Assembly | SB42159 |
| 8. | 1 | Spring-Adjusting Screw | SB24765 |
| 9. | 1 | Shoe Lever | SB18502-95 |
| 10. | 1 | Travel Link | SB17917-95 |
| 11. | 1 | Locknut | 05962 |
| 12. | 2 | 5/16" Star Washer | 05424 |
| 13. | 1 | Pin-Front Shoe | 05824 |
| 14. | 2 | Retaining Ring | SB7778 |
| 15. | 1 | Spring-Shoe | SB9786 |
| 16. | 1 | Spring-Lever | SB9785 |
| 17. | 2 | Spring-Shoe Return | SB6814 |
| 18. | 1 | Pin-Shoe Hold Down #4 | SB18505 |
| 19. | 4 | Cup-Shoe Hold Down | SB9789 |
| 20. | 1 | Spring-Hold Down -Maroon | 9790 |
| 21. | 1 | Spring-Hold Down - Blue | 9791 |
| 22. | 2 | Cover Plate-Adjusting Hole | 9254 |
| 23. | 1 | Pin-Shoe Hold Down #1 | 03562 |
| 24. | 1 | Washer-Shoe Guide | 18950 |
| 25. | 1 | Hex Cap Screw-1/4-20 UNC x 3/4 | 12972 |

8012DT

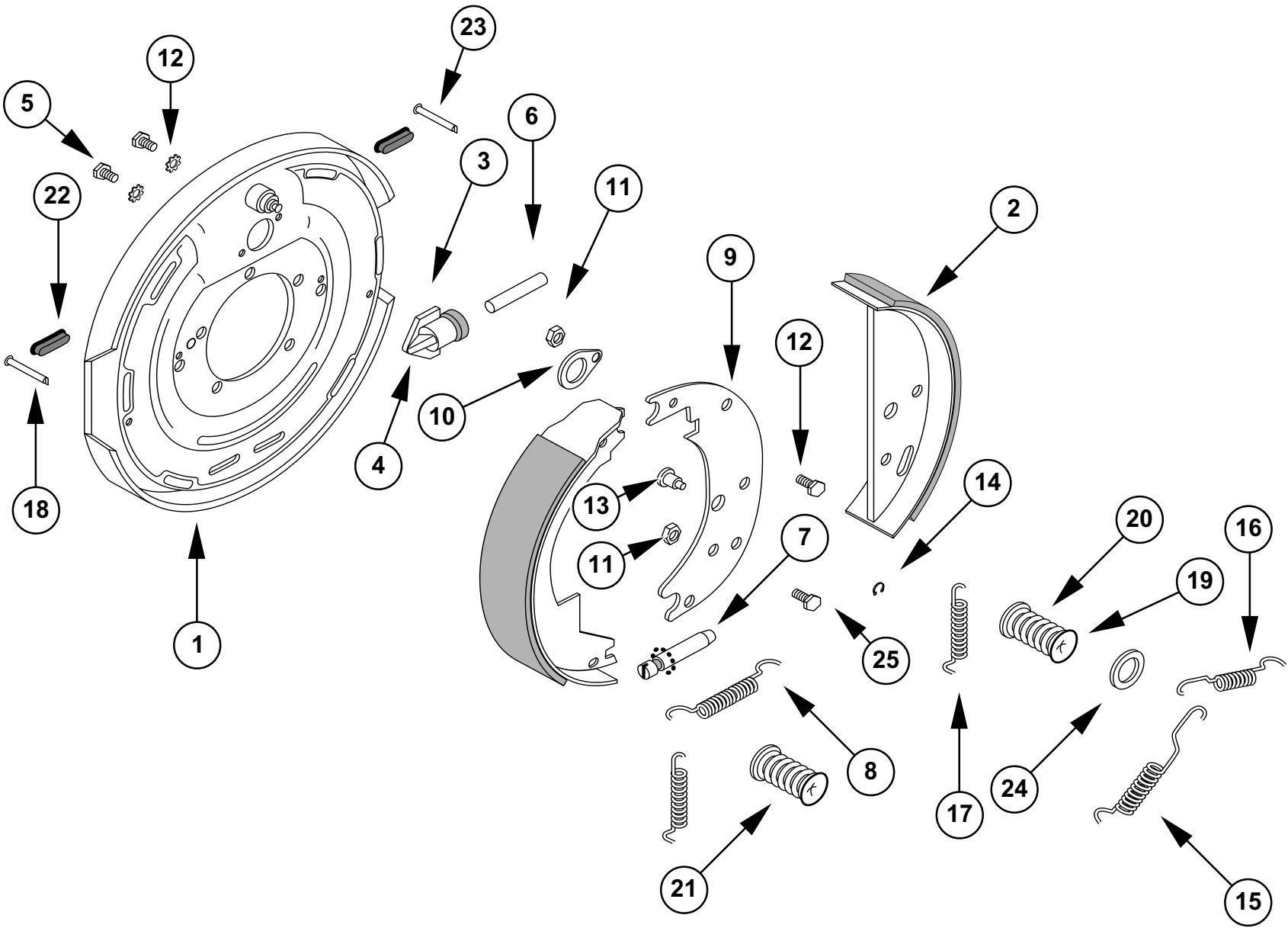

PARTS

TRAILMAX[®]

Parts

8012DT

Electric Brake Components, 7K

| Ref. | Quantity | Description | Part No. |
|------|----------|----------------------------------|------------|
| | 1 | LH Complete Brake Assembly | 023-105-00 |
| | 1 | RH Complete Brake Assembly | 023-106-00 |
| 1. | 1 | Backing Plate Assembly | 036-089-05 |
| 2. | 1 | LH Lever Actuating Arm | 047-107-00 |
| 2. | 1 | RH Lever Actuating Arm | 047-108-00 |
| 3. | 2 | Wire Clip | 027-005-00 |
| 4. | 2 | Retractor Spring | 046-009-00 |
| | 1 | Shoe and Lining Kit | K71-048-00 |
| 5. | 1 | Primary Shoe and Lining | 040-044-00 |
| 6. | 1 | Secondary Shoe and Lining | 040-045-00 |
| 7. | 2 | Shoe Hold Down Pin | 049-011-00 |
| 8. | 2 | Shoe Hold Down Spring | 048-077-00 |
| 9. | 1 | Adjuster Assembly | 043-004-00 |
| 10. | 1 | Adjusting Screw Spring | 046-018-00 |
| | 1 | Magnet Kit | K71-105-00 |
| 11. | 1 | Magnet (white wire) | 042-099-01 |
| 12. | 1 | Magnet Clip | 027-009-00 |
| 13. | 1 | Magnet Spring | 046-080-00 |
| 14. | 1 | Plug | 046-007-00 |
| 15. | 1 | Wire Grommet | 046-016-00 |
| 16. | 1 | Anchor Post Washer | 005-067-00 |
| 17. | 5 | Nut Washer Assembly | 006-193-00 |

Note: Kit names are **bold type** while component names are regular type; kit components, if itemized, are indexed under the kit name. Kit component quantities are per kit; other parts and kit quantities are per trailer.

8012DT

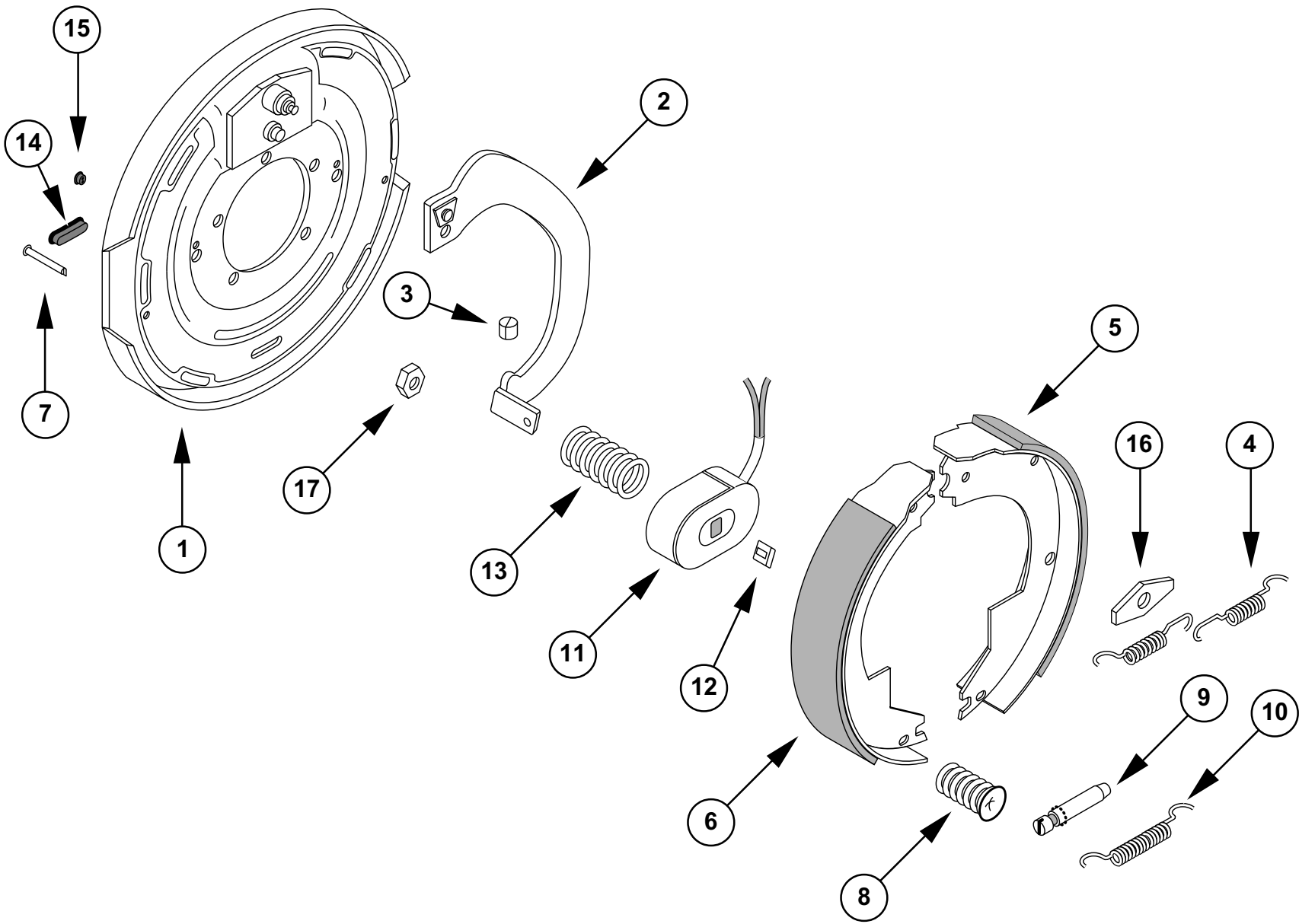

PARTS

TRAILMAX[®]

Parts

8012DT

Axle End Components

| Ref. | Quantity | Description | Part No. |
|------|----------|--|------------|
| 1. | 1 | Grease Seal | 010-036-00 |
| 2. | 1 | Inner Bearing Cone | 031-030-02 |
| 3. | 1 | Inner Bearing Cup | 031-030-01 |
| 4. | 6 | 1/2" Wheel Stud | 007-262-00 |
| 5. | 1 | Brake Drum (6 stud on 5.5" circle) | 008-201-09 |
| 6. | 1 | Outer Bearing Cup | 031-029-01 |
| 7. | 1 | Outer Bearing Cone | 031-029-02 |
| 8. | 1 | Spindle Washer | 005-023-00 |
| 9. | 1 | Spindle Nut Retainer | 006-190-00 |
| 10. | 1 | Spindle Nut (1"-14) | 006-176-00 |
| 11. | 1 | Grease Cap | 021-042-01 |
| 12. | 1 | Rubber Plug | 085-001-00 |

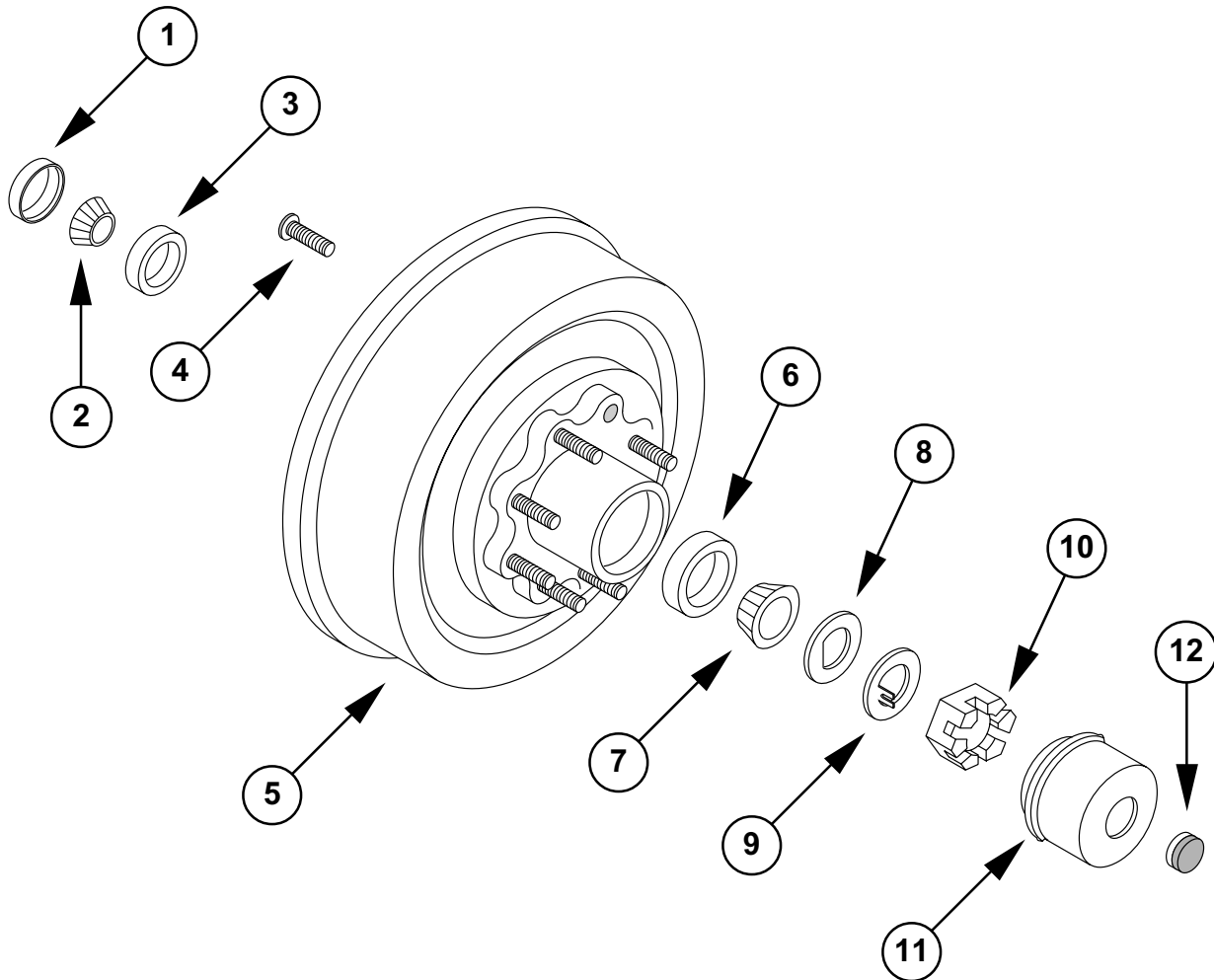

Parts

TRAILMAX[®]

3.4 Wheels and Tires

| Ref. | Quantity | Description | Part No. |
|------|----------|-------------------------------|--------------|
| 1. | 1 | Tire | ST235/80R16 |
| 2. | 1 | Wheel | 17-153-14 SP |
| 3. | 8 | Wheel Nut, 1/2"-20, 60° | 006-080-00 |

Note: Tires are not available through Gem State Manufacturing; contact your local equipment tire retailer for replacement parts.

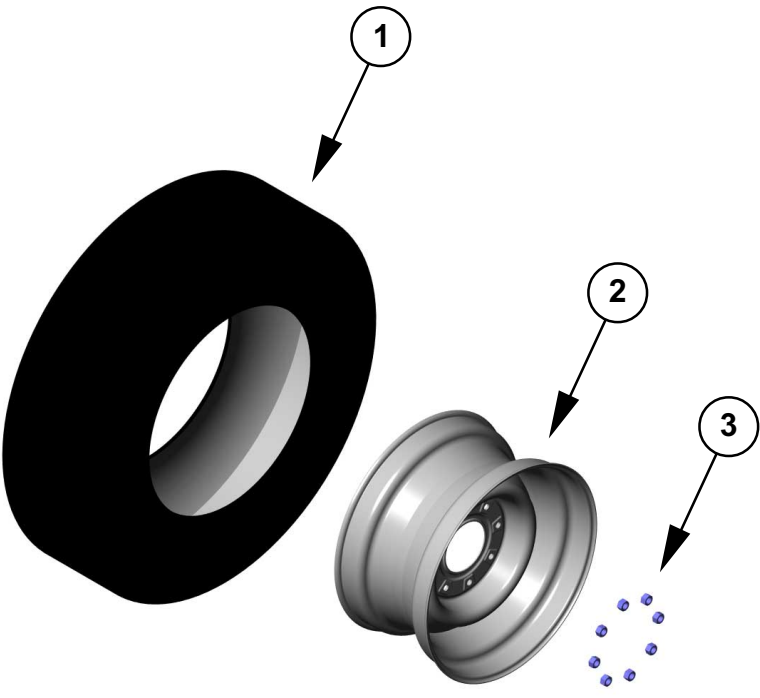

PARTS

8012DT

3.5 Electrical

Harnesses and Lights

| Ref. | Quantity | Description | Part No. |
|------|----------|---|------------|
| | 1 | E-14 Electrical Kit | K01946 |
| 1. | 5 | Red Clearance Lamp, sealed | 10205R |
| 2. | 7 | Mounting Grommet | 10704 |
| 3. | 2 | Amber Clearance Lamp, sealed | 10205Y |
| 4. | 2 | Oval Stop/Turn/Tail Light, sealed | 60202R |
| 5. | 2 | Oval Mounting Grommet | 60700 |
| 6. | 1 | License Plate Lamp | 26331 |
| 7. | 1 | Main Harness | 51437 |
| 8. | 2 | Marker/Clearance Harness | 50321 0216 |
| 9. | 1 | Tail Light Harness | 51305 |
| 10. | 1 | Electric Brake Jumper | 51436 |

Note: Kit names are **bold type** while component names are regular type; kit components, if itemized, are indexed under the kit name. Kit component quantities are per kit; other parts and kit quantities are per trailer.

8012DT

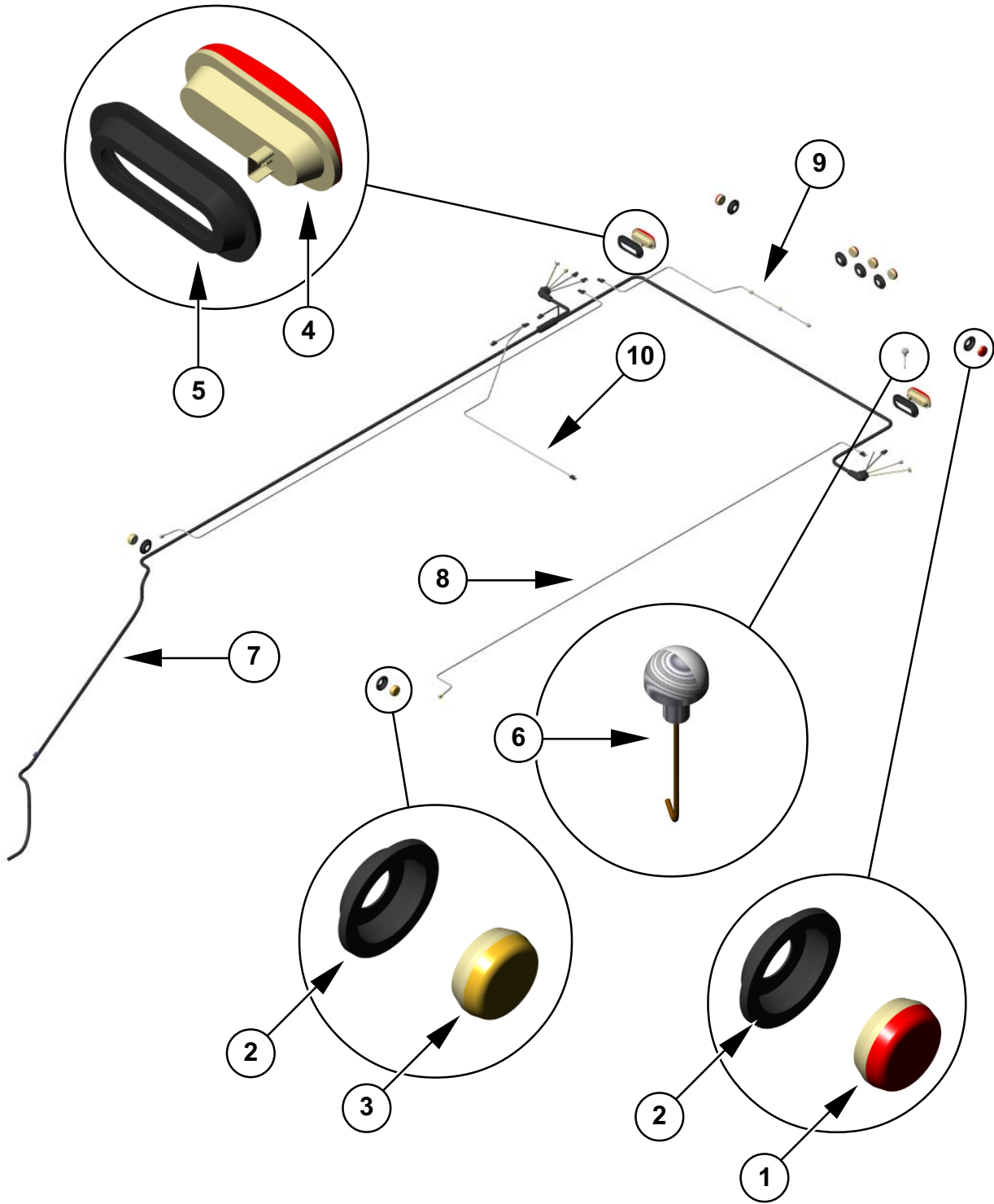

PARTS

8012DT

Electrical Plug

| Ref. | Quantity | Description | Part No. |
|----------------|----------|---------------------------------|-----------|
| 1. | 1 | Seven Way RV Plug | 12-706 |
| Options | | | |
| 2. | 1 | Seven Way Plug and Spring | PL 15-730 |
| 3. | 1 | Six Way Plug | S603 |

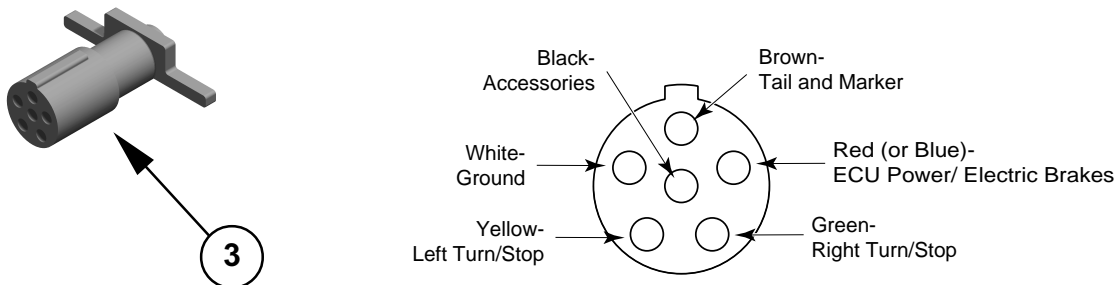
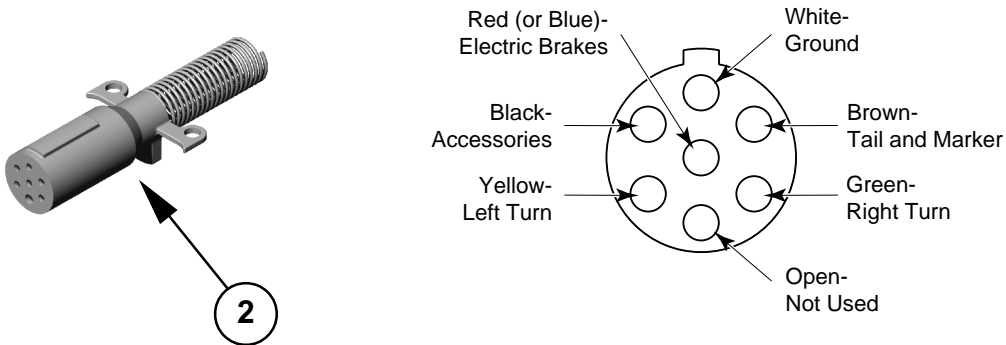
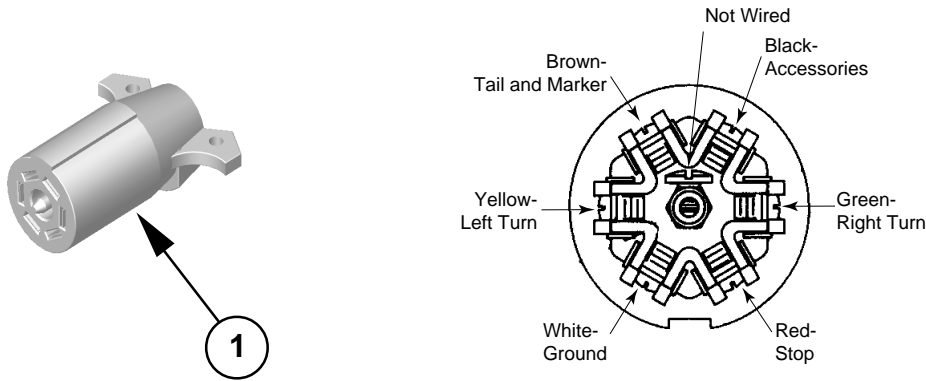

Electric Brake Wiring

| Ref. | Quantity | Description | Part No. |
|------|----------|------------------------------------|------------|
| | | E-8 Brake Harness Kit | K00769 |
| 1. | 1 | Brake Harness | 51362 0012 |
| 2. | 1 | Brake Harness | 51362 0096 |
| 3. | 4 | Magnet Pigtail | 94619 |

Note: Kit names are **bold type** while component names are regular type; kit components, if itemized, are indexed under the kit name. Kit component quantities are per kit; other parts and kit quantities are per trailer.

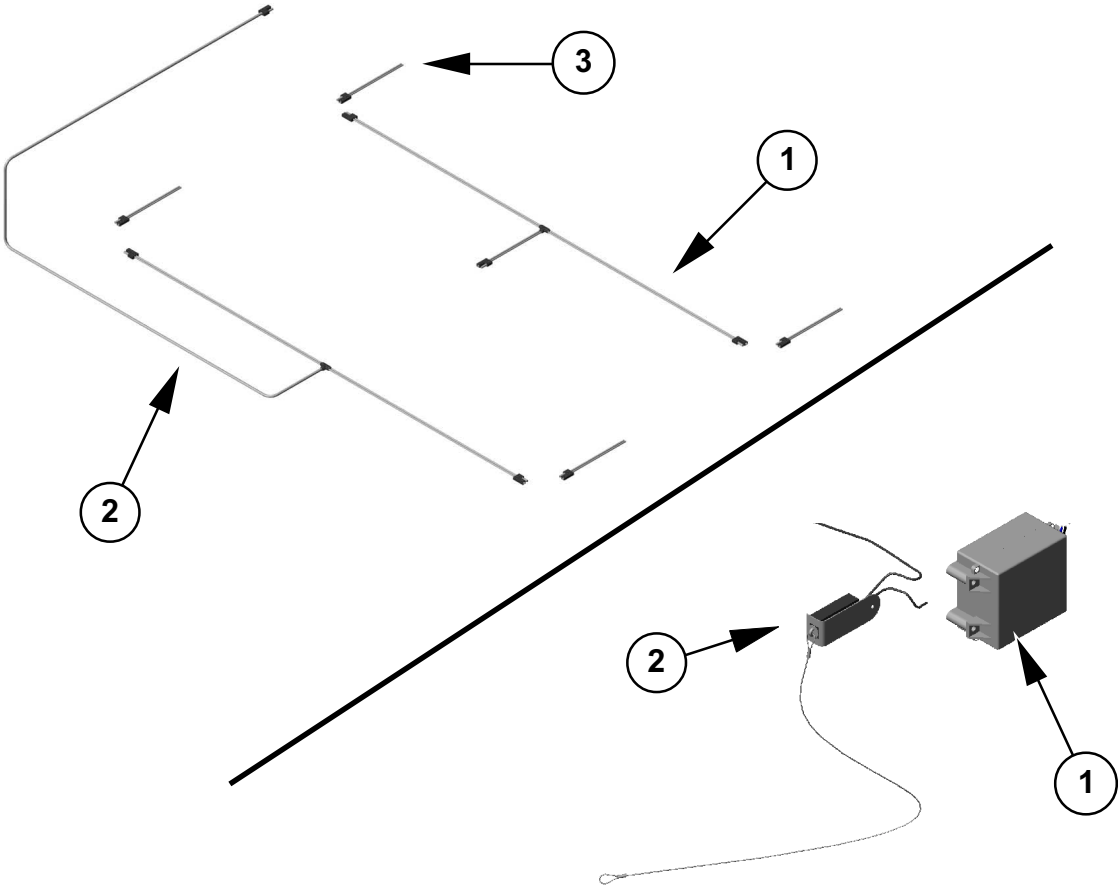

Electric Breakaway System

| Ref. | Quantity | Description | Part No. |
|------|----------|---|----------|
| 1. | 1 | Electric Breakaway Kit W/O Switch | 20017 |
| 2. | 1 | Electric Breakaway Switch W/44" Leads | 20014 |

PARTS

8012DT

3.6 Hydraulic System

Hydraulic Lines

| Ref. | Quantity | Description | Part No. |
|------|----------|------------------------------------|------------|
| | | Surge Line Kit | 0716-04 |
| 1. | 4 | Brake Hose, 13" | 18013-FF |
| 2. | 5 | Hose Bracket | 25 x 15 |
| 3. | 4 | Hose Clip | 1457 |
| 4. | 3 | Adapter Tee | 7900 |
| 5. | 1 | Brake Line, 113" | AG-16113-C |
| 6. | 2 | Brake Line, 62" | T-16062-C |
| 7. | 1 | Brake Line, 71" | T-16071-C |
| 8. | 8 | 1/4" Loom Clamp | A0250 |
| | | Finish Surge Line Kit | 0716-08 |
| 9. | 1 | Brake Hose, 13" | 18013-MF |
| 10. | 4 | Hose Clip | 1457 |

Note: Kit names are **bold type** while component names are regular type; kit components, if itemized, are indexed under the kit name. Kit component quantities are per kit; other parts and kit quantities are per trailer.

8012DT

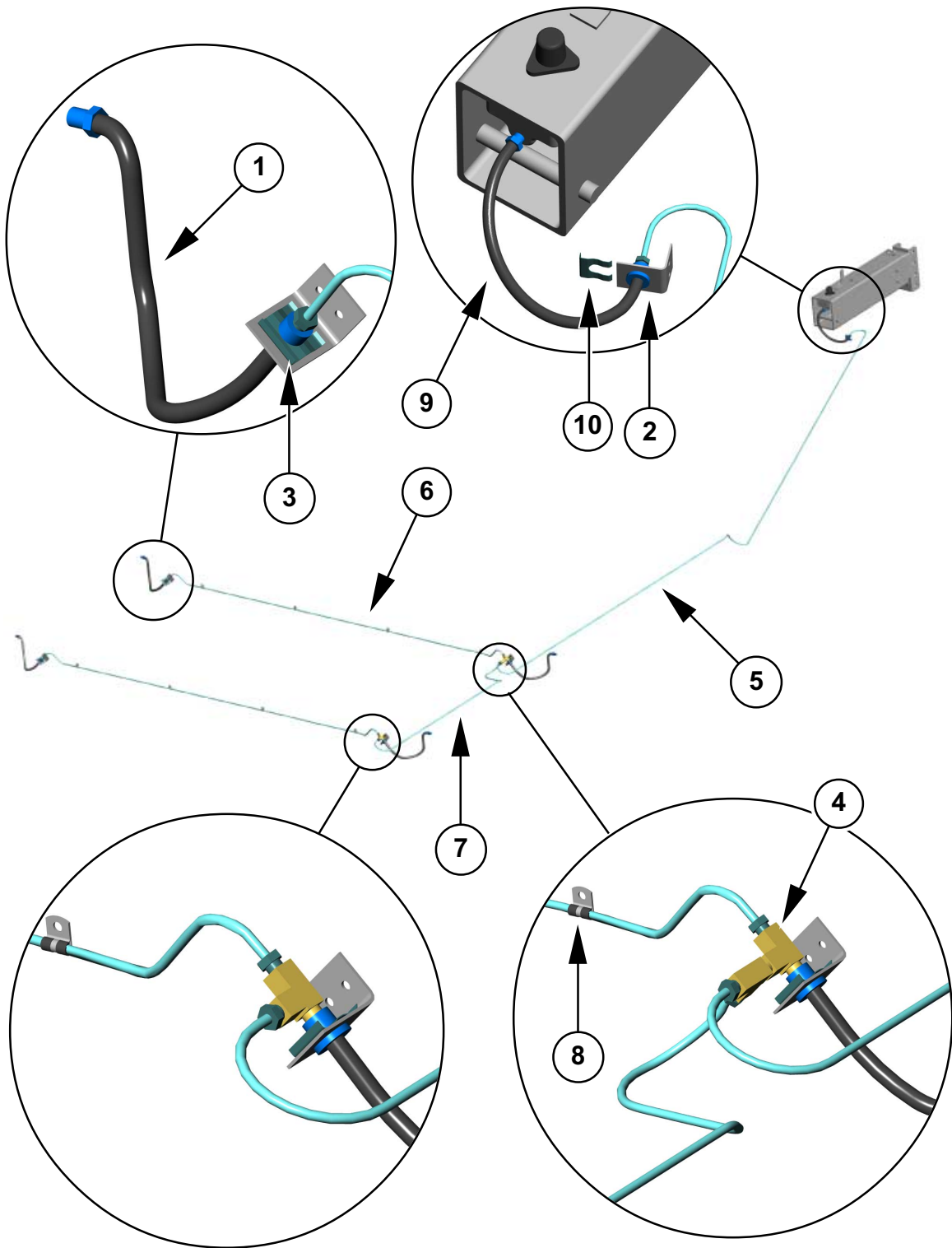

PARTS

8012DT

Model DA20 Surge Actuator

| Ref. | Quantity | Description | Part No. |
|------|----------|---|----------|
| 1. | 1 | Inner Slider Tube Channel Centered | 11044-97 |
| 2. | 1 | Top Wear Pad | 10962 |
| 3. | 1 | Bottom Wear Pad | 10963 |
| 4. | 2 | Spacer Block..... | 10964 |
| 5. | 2 | Damper Shock | SB12426 |
| 6. | 1 | Front Shock Pin | 03409-95 |
| 7. | 1 | Outer Case | 03412-97 |
| 8. | 2 | Connecting Pin | 03411-95 |
| 9. | 6 | 5/32" x 1-1/4" Cotter Pin | 02363 |
| 10. | 1 | Rear Shock Pin | 03410-95 |
| 11. | 1 | Emergency Lever Spring | 05693-95 |
| 12. | 2 | 5/16"-18 UNC x 5/8" Hex Head Bolt Grade 5 | 05961 |
| 13. | 2 | 5/16" External Tooth Lock Washer | 05424 |
| 14.. | 4 | 1/4"-20 UNC x 2" Hex Head Bolt Grade 5 | 00618 |
| 15. | 4 | 1/4" Lock Washer | 00057 |
| 16. | 1 | Emergency Lever | 05951 |
| 17. | 1 | Push Rod Assembly | 03534 |
| 18. | 1 | Composite Master Cylinder w/gasket 09153 | 05650 |
| 19. | 1 | Master Cylinder Gasket | 09153 |
| 20. | 1 | 1/8" pipe - 3/16" Inverted Flare Fitting w/ orifice | 05679 |
| 21. | 1 | Master Cylinder Cap w/ Diaphragm and O-ring | 03876 |
| | | Replacement O-ring | 05849 |
| 22. | 1 | 3/32" Cable Assembly w/ hooks | 05408 |
| | | Replacement S-hooks | SB10555 |
| 23. | 1 | Lever Guide | 03866-95 |
| 24. | 1 | Master Cylinder Protective Boot | 05687 |
| | | Decal- Towable/Not Towable | BH21003 |
| 25. | 4 | 1/4"-20 UNC Hex Nuts | 00062 |

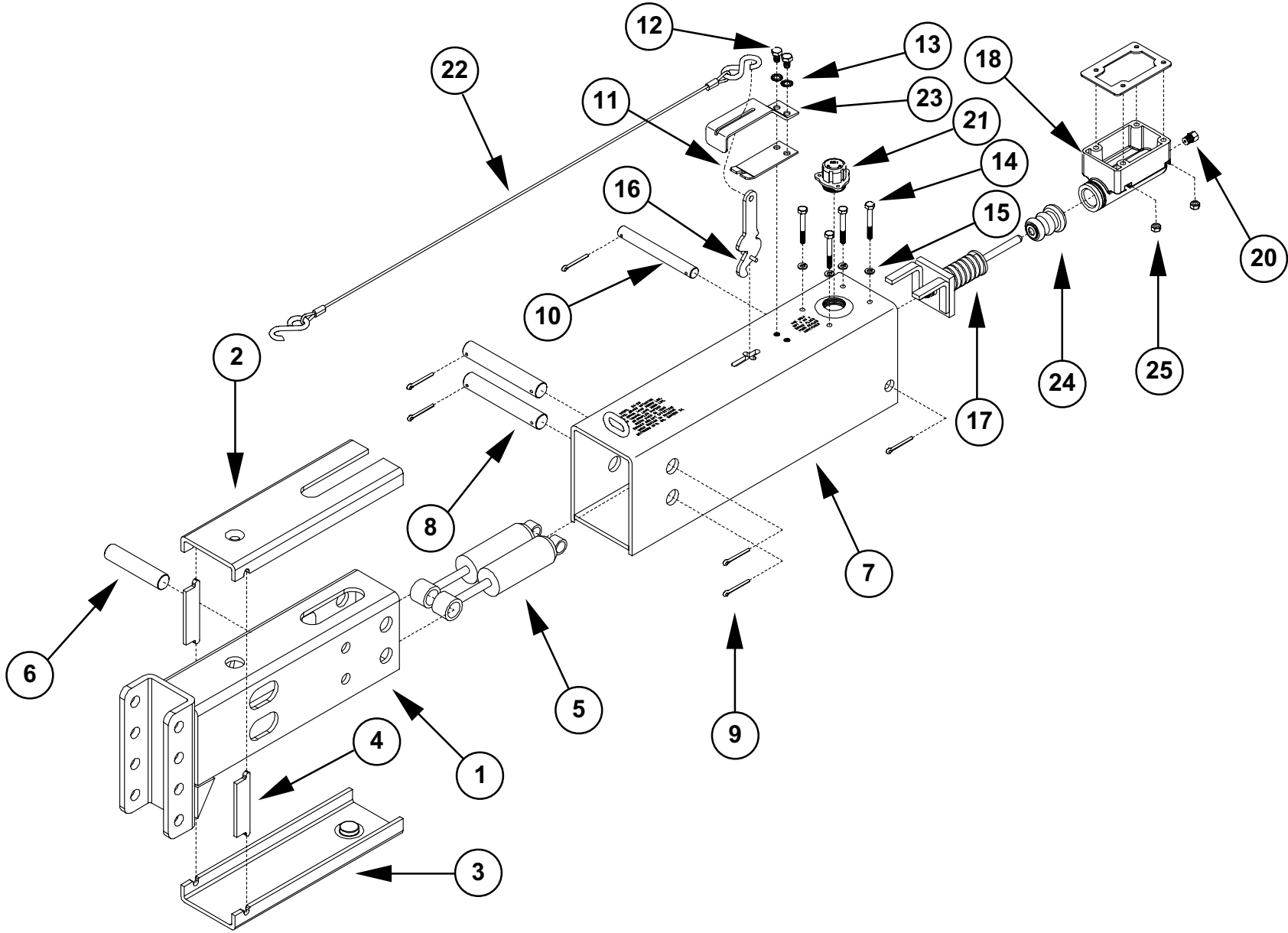

8012DT

Power Unit Motor

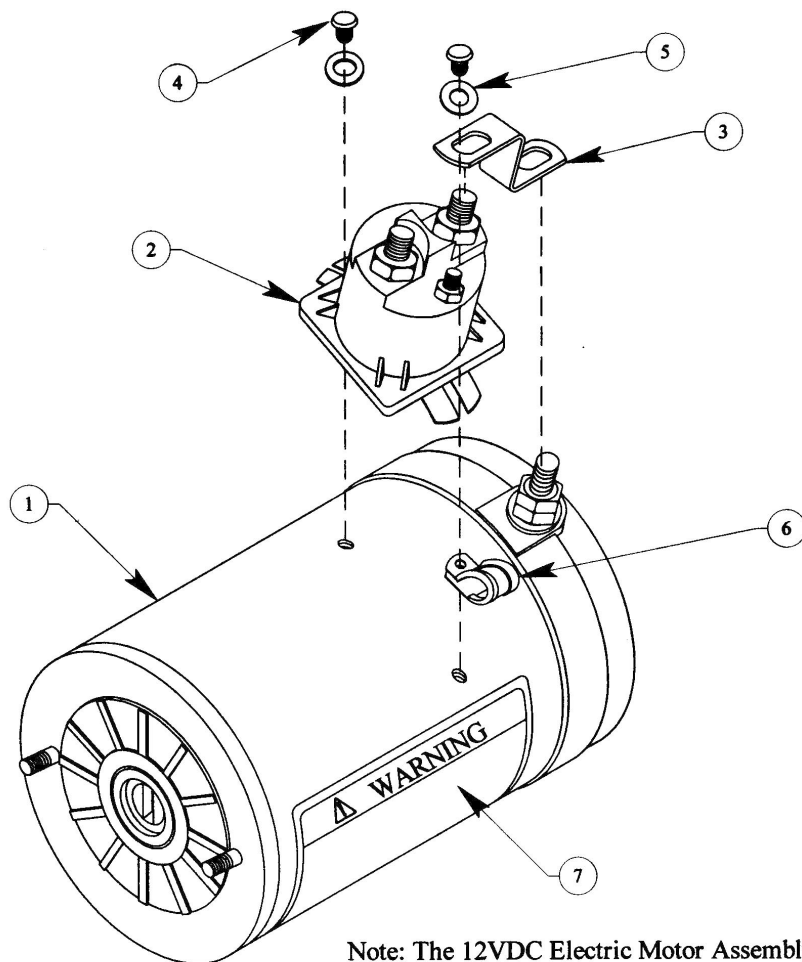

Note: The 12VDC Electric Motor Assembly Can Be Ordered Complete as P/N 2654

| Drawing No. | Part No. | Quantity Req'd | Part Description |
|-------------|----------|----------------|--|
| 1 | 2613 | 1 | DC Motor |
| 2 | 2521 | 1 | Solenoid, 12 VDC Phenolic |
| 3 | 2511 | 1 | Copper Strap |
| 4 | — | 2 | 10-32 x 9/32" Thread roll T25 Torx Drive |
| 5 | 1805 | 2 | Washer, 1/4" ID x 5/8" OD Plain |
| 6 | 2066 | 1 | Clamp, 3/8" |
| 7 | 1974 | 1 | Decal, Warning: Wire Size Reqm. |

THIS PAGE LEFT BLANK INTENTIONALLY

8012DT

Power Unit Control Valve

#15 Control Valve Assembly

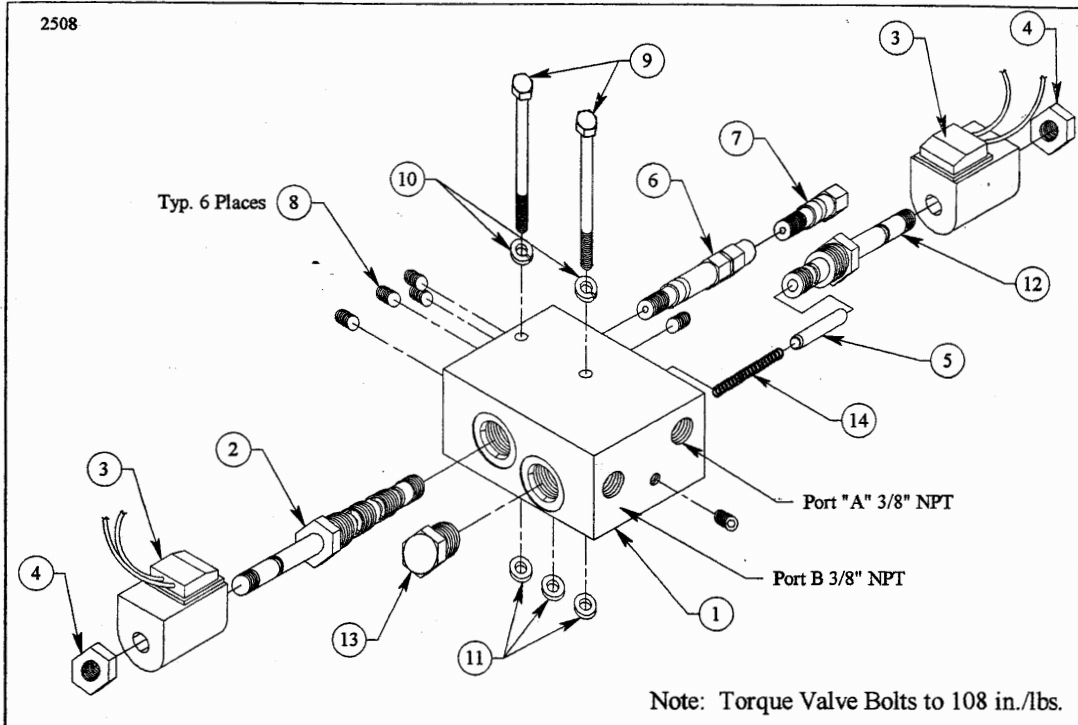

| Drawing No. | Part No. | Quantity Req'd | Part Description |
|-------------|----------|----------------|--|
| 1 | 2497 | 1 | Block, Solenoid Valve |
| 2 | 2704 | 1 | Cartridge Only, 4-Way, 2-Position, Valve |
| 3A | 2705 | 2 | 12 Volt Coil |
| 3B | 2706 | 2 | 24 Volt Coil |
| 3C | 2707 | 2 | 110 Volt Coil |
| 3D | 2708 | 2 | 220 Volt Coil |
| 4 | | 2 | Cartridge Valve Nut |
| 5 | 2498 | 1 | Flow Control, Pressure Compensated |
| 6 | 1575 | 1 | Relief Valve, Port (Optional) |
| 7 | 1641 | 1 | Plug, Relief Valve (Optional) |
| 8 | 1579 | 6 | Plug, 1/16" NPT w/Sealant |
| 9 | 1937 | 2 | Cap Screw, 1/4" - 20 UNC x 2.5" Long, Grade 8 |
| 10 | 1290 | 2 | Washer, Lock (1/4" I.D.) |
| 11 | 1606 | 3 | O - Ring, #2 - 010 Valve Seal |
| 12 | 2703 | 1 | Cartridge Only, 2-Way, 2-Position, N/C Check Valve |
| 13 | 1969 | 1 | Plug, #8 ORB 3/4" - 16 |
| 14 | 2500 | 1 | Spring, Flow Control |

Power Unit Control Valve Schematic

#15 Valve Schematic

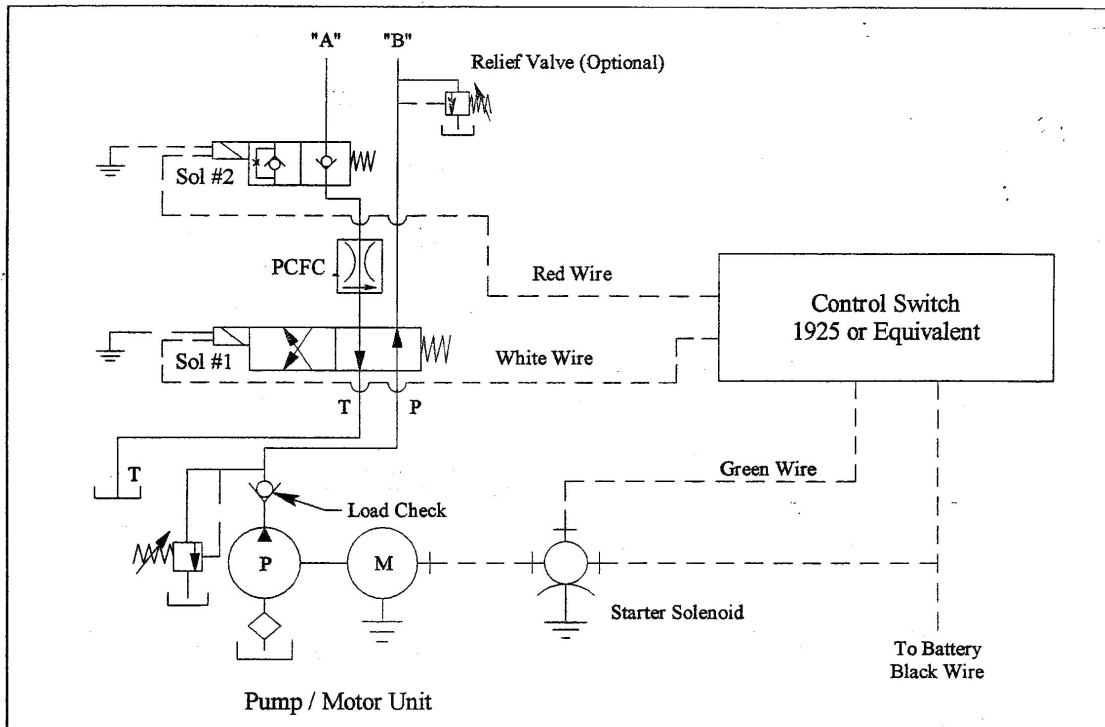

System Function

Energizing Power unit and Sol # 1, oil is directed to Port "A" and oil from Port "B" is directed back to tank ("T" Port).

Energizing Power unit and Sol # 2, oil is directed to Port "B" and oil from Port "A" is directed back to tank ("T" Port).

Application

1. Power up / Power Down
2. Power extend / Power retract

Valve Characteristics

1. Uses one 4-way, 2-position spool type cartridge valve and one 2-way NC P.O. poppet type check valve, solenoid operated.
2. Aluminum manifold block machined for one 4-way, 2-position cartridge valve, two 2-way check valves (plugging one cavity in this application) and with two 3/8" NPT Ports.
3. Pressure compensated flow control.

Limitations

1. When lifting and/or holding a load, use port "A".
2. If valve is used in an application in which a cylinder is to be lowered with a load on it (overriding load), it should be noted that pressure surges can occur in the load holding hose.
3. This valve is stackable from the factory up to three valves.
4. Horizontal Mounting.

2507

8012DT

Gear Pump and Manifold Assembly Parts List

| Drawing No. | Part No. | Quantity Req'd | Part Description |
|-------------|----------|----------------|--|
| 1 | - | 1 | Manifold, Machined |
| 2 | 1588 | 1 | Relief Assembly, Pump |
| 3 | 1606 | 1 | O-Ring, 3/8 OD x 1/4 ID x 1/16 Thk. (2-010) |
| 4 | 2439 | 1 | Adapter, Electric Gear Pump |
| 5 | 1579 | 1 | Plug, 1/16 NPT W/ Sealant |
| 6 | 2465 | 1 | O-Ring, 9/16 OD x 7/16 ID x 1/16 Thk. (2-013) |
| 7 | 2466 | 1 | Spring, Gear Pump load check |
| 8 | 1168 | 1 | Bearing, 3/8" Chrome Ball |
| 9 | 2467 | 3 | Cap Screw, 5/16 - 18 x 3/4, Socket Head |
| 10 | 2470 | 1 | Pilot O-Ring, 1-1/4 O.D. x 1-1/8 I.D. x 1/16" Thk. (2-024) |
| 11A | 2432 | 1 | GC8000, .097 Cubic Inch Disp. (Kit) |
| 11B | 2433 | 1 | GC8000, .129 Cubic Inch Disp. (Kit) |
| 11C | 2434 | 1 | GC8000, .194 Cubic Inch Disp. (Kit) |
| 12 | 2472 | 1 | O-Ring, 11/16 O.D. x 1/2 I.D. x 3/32" Thk. (2-112) |
| 13 | Kit | 1 | Self Tapping Screw |
| 14 | 2473 | 4 | Cap Screw, 1/4 - 20 x 2" Long, Socket Head |
| 15 | 1290 | 4 | Washer, 1/4" Split Lock |
| 16 | Kit | 1 | Oldham Coupling |
| 17 | 2471 | 1 | O-Ring, 7/16 O.D. x 5/16 I.D. x 1/16" Dia. (2-011) |
| 18 | Kit | 2 | Inlet Tube Brackets |
| 19A | Kit | 1 | Inlet Tube 90° (Round Horizontal Reservoirs) |
| 19B | - | 1 | 2474, 2475, 2476 (Round Vertical Reservoirs) |
| 19C | - | 1 | 2469 Inlet Tube 60° (Square Reservoirs) |
| 20 | Kit | 1 | Inlet Screen |
| 21 | 1399 | 1 | Port Stud No Pin |

NOTE: Item 11 comes complete with items 10, 12, 13, 14, 15, 16, 17, 18, 19, 20.

Gear Pump and Manifold Assembly Parts Illustration

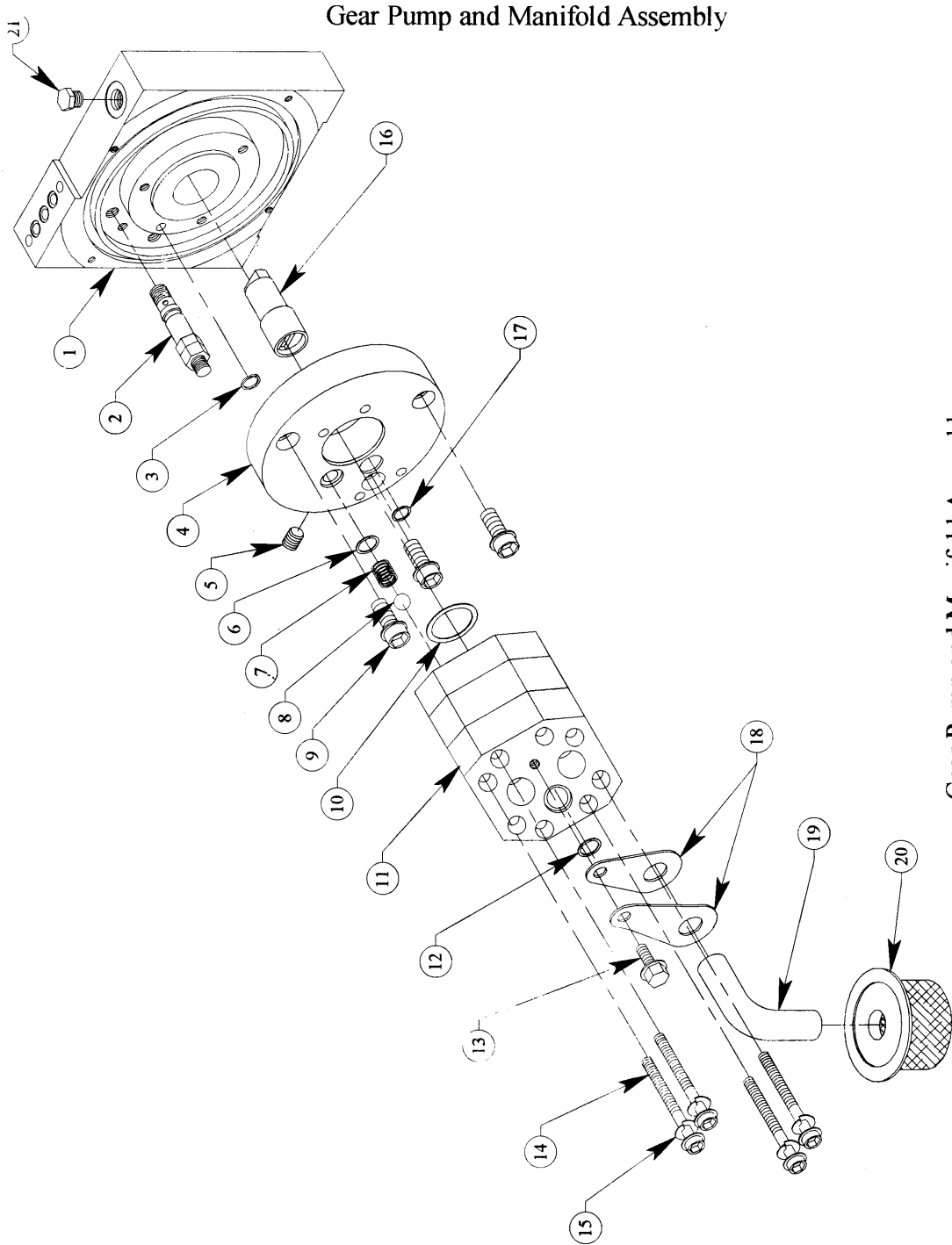

Gear Pump and Manifold Assembly

PARTS

8012DT

3.7 Tool Box

| Ref. | Quantity | Description | Part No. |
|------|----------|-------------------|-----------|
| 1. | 1 | Tool Box | TM321 421 |

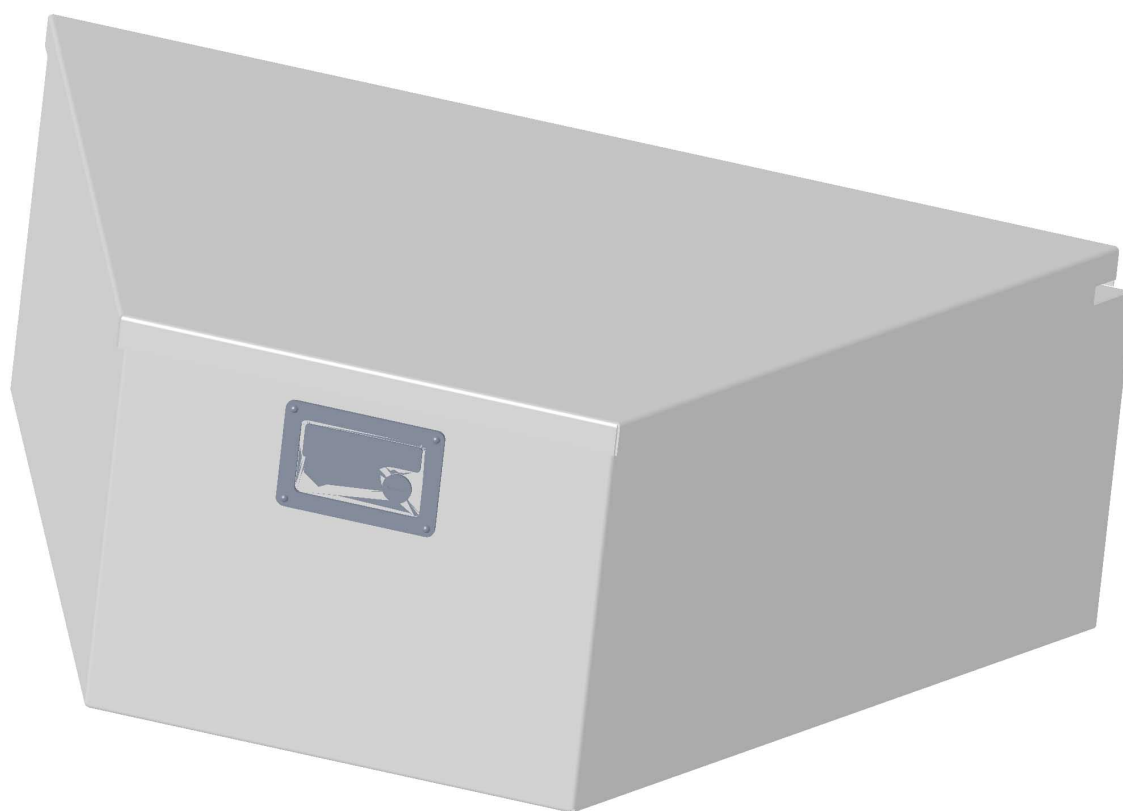

THIS PAGE LEFT BLANK INTENTIONALLY

Section 4. Warranty Claim Procedure

At Gem State Manufacturing, we insist on a high level of quality materials and workmanship that go into every TrailMax trailer. Ultimately this will minimize the need for frequent service and warranty claims. However, in the event of a claim, we want to be as responsive as possible.

In the event that you have a problem with your trailer that may be warranty related, your cooperation is appreciated when the following steps are followed in an effort to process the claim expeditiously.

1. Have the trailer V.I.N. (Vehicle Identification 17 digit Number) and model No. available.
2. Refer to the Operators Manual when identifying defective parts. If the claim is structural related, photos may be required and are helpful in determining how to correct the problem. (Digital photo's can be sent via e-mail to customerservice@trailmax.com in *.jpg or *.jpeg format.)
3. Contact a TrailMax representative in your immediate area. If you do not have or can not find a representative in your area, then contact the factory Warranty Administrator for assistance @ 1-800-447-0213.
4. Give a detailed description and nature of the problem. Also leave contact name(s), phone no. and/or e-mail address.
5. A claim will be processed and reviewed for warranty approval. The factory Warranty Administrator must authorize all Warranty Claims before repairs can be made.

Note: All work must be done by an authorized TrailMax warranty station. Should you choose to make repairs prior to approval, you could assume full responsibility for repairs.

6. Defective parts must be returned to Gem State Manufacturing at 1705 Industrial Way, Caldwell, Idaho, 83605, for evaluation unless otherwise instructed.
7. Please make sure you have followed the procedure all the way through, failure to do so could hold up final process of Warranty Claim and approval for payment.

Our ultimate goal is to retain satisfied customers. Your cooperation is appreciated, as we will process the claim as expeditiously as possible to get you back in service.