

TD-24-T (5+20)

Table of Contents

| | |
|----------------------------------------------------|-----------|
| Section 1. Operation | 3 |
| 1.0 Introduction | 3 |
| 1.1 Purpose | 3 |
| 1.2 Rating | 3 |
| 1.3 Design and Safety Factors | 4 |
| 1.4 Vehicle Load and Handling Limits | 4 |
| 1.5 Alert Symbols | 7 |
| 1.6 Uncaging Air Brakes | 8 |
| 1.7 Reporting Safety Defects | 10 |
| 1.8 Pre-Trip Inspection | 11 |
| 1.9 Hook-Up Procedures | 12 |
| 1.10 Loading and Unloading | 13 |
| Trailers With Ramps | 14 |
| Trailers With Tilt Decks | 14 |
| Section 2. Maintenance | 15 |
| 2.0 Periodic Maintenance | 15 |
| 2.1 Structural Components | 16 |
| Sub-Frame | 16 |
| Deck | 16 |
| 2.2 Sub-Assembly Components | 16 |
| Drawbar Eye | 16 |
| Binkley Jack | 17 |
| Cushion Cylinder | 17 |
| Deck Latch | 17 |
| Deck Hinge Assembly | 17 |
| 2.3 Rear Impact Guard (RIG) | 18 |
| 2.4 Running Gear | 19 |
| Suspension | 19 |
| Axle Alignment | 21 |
| Hubs and Drums | 22 |
| Hub Inspection | 22 |
| Broken or Damaged Studs | 22 |
| Brake Drum Inspection | 23 |
| Brake Drum Troubleshooting Chart | 24 |
| Brake Drum Troubleshooting Chart (continued) | 25 |
| Bearing Inspection | 26 |
| Bearing Lubrication | 26 |
| Seal Inspection and Replacement | 27 |
| Hub Reinstallation and Bearing Adjustment | 27 |
| 2.5 Wheels and Tires | 28 |
| Wheels | 28 |
| Wheel Torquing Procedures | 30 |
| Tires | 31 |
| Inflation Pressure | 31 |
| Tire Wear Diagnostic Chart | 32 |

TD-24-T (5+20)

| | | |
|-------------------|---------------------------------------------------|-----------|
| 2.6 | Electrical | 33 |
| | Harnesses and Lights | 33 |
| | Junction Block | 33 |
| | Seven-Way Plug | 33 |
| 2.7 | Air Brake System | 34 |
| | General Air Brake Maintenance | 34 |
| | Automatic Slack Adjuster Maintenance | 35 |
| | Manual Brake Adjustment | 36 |
| | Slack Adjuster Function Test | 37 |
| 2.8 | Electric Brake System | 38 |
| | Operation | 38 |
| | Using your Brakes Properly | 39 |
| | Synchronization | 40 |
| | Controllers | 41 |
| | Magnets | 41 |
| | Brake Cleaning and Inspection | 42 |
| | Brake Lubrication | 42 |
| | Shoes and Linings | 42 |
| | Electric Brake System Troubleshooting | 43 |
| | Measuring Voltage | 43 |
| | Measuring Amperage | 45 |
| | Manual Brake Adjustment | 46 |
| | Electric Brake System Troubleshooting Chart | 47 |
| 2.9 | Pre-Storage Maintenance | 48 |
| 2.10 | Pre-Season Maintenance | 49 |
| Section 3. | Parts | 50 |
| 3.1 | Structural Components | 50 |
| | Sub-frame | 50 |
| | Deck Assemblies | 51 |
| 3.2 | Major Sub-Assemblies | 52 |
| | Drawbar Eye | 52 |
| | Binkley Jack | 53 |
| | Cushion Cylinder | 54 |
| | Deck Latch Assembly | 55 |
| | Deck Hinge Assembly | 56 |
| 3.3 | Rear Impact Guard (RIG) Assembly | 57 |
| 3.4 | Running Gear, 12K | 58 |
| | Suspension | 58 |
| | Axle End Components, 12K | 60 |
| | Air Brake Components, 12K | 62 |
| | Electric Brake Components, 12K | 64 |
| 3.5 | Wheels and Tires | 66 |
| 3.6 | Electrical | 68 |
| | Harnesses and Lights | 68 |
| | Electrical Plug | 70 |
| | ABS Electrical | 70 |
| | Electric Breakaway System | 73 |
| 3.7 | Air Brake System | 74 |
| Section 4. | Warranty Claim Procedure | 78 |

Section 1. Operation

1.0 Introduction

This section describes how trailers can have different operational characteristics based on design, load configuration, gross weights, suspension characteristics, articulation and extreme differences between loaded and unloaded weights.

Trailers have safe operating limits just as automobiles, airplanes, and other vehicles. The interaction of the vehicle characteristics, maintenance, load, roadway, weather, the skill of the driver and vehicle speed affect these limits. Knowledge of how these factors affect the vehicle's operating limits and utilization of defensive driving techniques should result in safer driving.

1.1 Purpose

The purpose of this section is to describe how the vehicle characteristics, maintenance, road conditions, and weather can affect trailer control and stability limits, and how driver awareness and skill can help compensate for these factors. This knowledge will assist you to safely enjoy the maximum utility and productivity from your trailer.

First and foremost, DO NOT operate the trailer until you have read and fully understand this instruction and operating manual. It is also important that each and every person who operates the trailer be given the opportunity to read this manual.

1.2 Rating

Gross Axle Weight Rating (GAWR) is the rated load-carrying capacity of an individual axle and wheel assembly. It represents the load that may be steadily sustained by the components in the system; i.e., tires, wheels, hubs, bearings, axles, brakes, suspension, sub-frame, etc. with the GAWR limited by the component with the lowest working rating. Consideration of environmental and operational factors may require the manufacturer to reduce the nominal rating.

Gross Vehicle Weight Rating (GVWR) is the maximum rated combined weight of a trailer and its payload (uniformly distributed) based on its structural capabilities.

TD-24-T (5+20)

1.3 Design and Safety Factors

The safety factor is a ratio between the design stress imposed by the load sitting static on the trailer and the minimum yield stress of the steel used in construction of that trailer structure. For example, if the structure is built using 50,000 psi minimum yield strength steel and the load sitting on it causes a stress level of 25,000 psi then a 2:1 safety factor would exist. THIS SAFETY FACTOR DOES NOT MEAN THAT THE STRUCTURE CAN THEN BE USED TO CARRY TWICE THE RATED LOAD. Under dynamic conditions, or as the trailer moves and encounters shocks, vibrations, twists and other conditions that exist during transport, stress levels are elevated far beyond those in the static situation.

Distributed Load is when a load is distributed evenly over the length of the trailer deck. This would be considered as the ideal load scenario when fully loaded to rated capacity.

Concentrated Load is one that is localized over a shorter than normal distance and imposes greater stress in the concentrated load areas. Under these conditions, it is not recommended to carry the full rated capacity of the trailer. Extreme concentrated applications may require additional support for the load.

1.4 Vehicle Load and Handling Limits

Vehicle handling limits can be greatly affected by the weight of a load, its placement, the amount of weight distributed over the axles and whether or not the load is secured properly.

Tow vehicle and trailer combinations are designed to provide maximum directional control and roll stability within the constraints of highway size and weight limits. Any combination can be rolled over by driving too fast around a curve, making too abrupt a maneuver, or by leaving the roadway. Locking up the wheels on an axle can result in a jackknife or trailer swing out.

One of the major contributing factors to vehicle rollover is high center of gravity on tall loads. Extreme caution should be used in maneuvering a vehicle and trailer combination, or any unit that has a tall load. Positioning the load in a central side to side location will enhance directional control, roll stability and braking.

You should be aware that trailers with a shorter wheel base are more prone to roll during an abrupt lane change or quick reactions at the wheel. This tendency can be made dramatically worse with a tall, high center of gravity load.

TD-24-T (5+20)

Overloading a vehicle should never be permitted. Overloading results in tire blow-outs, spring breakage, frame damage, diminished braking capacity, and will severely alter the vehicle's normal handling characteristics. All vehicles are designed with a maximum load capability. To best utilize these vehicles in the safest manner the loads as shown on the certificate label should not be exceeded.

Adequate tongue weight is required for trailers to tow correctly. Inadequate tongue weight can cause a "whipping action" particularly in shorter wheel base trailers. Too much tongue weight can overload tow vehicle hitch resulting in reduced steering load and loss of steering control. Selecting the correct tow vehicle is crucial for the application.

Always maintain enough braking and stopping distance. Erratic or unequal brake action from side to side on either tow vehicle or trailer can cause handling problems in braking situations. A balance between tow vehicle and trailer on brake application and release timing and synchronized pressure will reduce push/pull characteristics which when excessive, may result in jackknife. The use of properly matched brake lining is recommended to enhance safer braking.

Proper alignment of both tow vehicle and trailer wheels will add significantly to the handling characteristics of the combination and allow the driver to utilize all the design responses of the vehicle to make evasive maneuvers in the safest manner.

Irregular terrain, steep grades and crowned roads, especially rural roadways, freeways, exit ramps, curves, bumps and depressions introduce forces into a tow vehicle/trailer combination that could result in an accident if proper precautions and driving techniques are not followed. Even a vehicle that meets all maintenance and load requirements can become hazardous when excessive speeds and certain roadway characteristics are combined.

While on a downgrade, the force of gravity works against the driver in maintaining control of the vehicle, particularly if the road surface is wet or slick from snow and ice or loose material. On upgrades, the problem is spinning out due to insufficient traction at the drive wheels, particularly on snow and ice.

Great care must be taken to avoid excessive use of brakes on long downgrades. Overheated brakes are dangerously inefficient. It is very dangerous to brake on a downgrade using only the trailer brakes. If this is done, the trailer brakes heat up and fade and the tow vehicle brakes alone will not be able to stop the combination by themselves. Drivers should reduce speed, downshift and use engine compression as the principal means of controlling speed on long grades and using all brakes so brake temperatures can be held to a safe level.

TD-24-T (5+20)

Weather conditions can be a major factor in the cause of accidents. Rain, ice, snow, high winds and visibility combined with excessive speed, sudden lane changes, or other factors that put lateral forces into a tow vehicle trailer combination contribute significantly to an accident.

Slippery roads can increase stopping distances and reduce the ability to control the vehicle. When the road is wet, the available tire/road friction may be half that of a dry road, and icy roads can reduce friction many times over wet roads. If hard braking or rapid acceleration occurs, there may be little or no friction available to prevent tire lateral movement and skidding results.

The driver has a responsibility to compensate for the characteristics and conditions of his vehicle, the road conditions and weather. Reducing speeds and increasing attentiveness may compensate for most of these conditions. The more familiar the driver is with the vehicle and the road, the less likely he will need to make abrupt emergency maneuvers which will take the vehicle to its limits. Control and stability may be maintained if the driver knows his vehicle, his load, and the road.

Either braking or accelerating while cornering can significantly reduce the controllability and stability of the vehicle and should be avoided. The best driving practice is to decelerate to a safe conservative speed before entering a corner or approaching congested traffic and then apply only moderate power until an essentially straight path has been established.

It is imperative that a safe speed always be maintained. The safe speed is that speed at which control can be maintained over the vehicle at all times. This speed will allow an emergency change of lane maneuver, travel off an exit ramp with a tightening radius and recovery from pavement drop-off or wet pavement. This speed will vary from one combination of vehicle to another and takes into consideration such factors as road conditions, weather, traffic, visibility, type of load and experience of the driver.

1.5 Alert Symbols

It is important that you know the meaning of the following symbols that are used throughout this document.



SAFETY ALERT!

This is the safety alert symbol. It is used to alert you to potential personal injury hazards. Obey all safety messages that follow this symbol to avoid possible injury or death.



DANGER!

DANGER! indicates an imminently hazardous situation which, if not avoided, will result in death or serious injury.



WARNING!

WARNING indicates a potentially hazardous situation which, if not avoided, could result in death or serious injury.



CAUTION!

CAUTION indicates a potentially hazardous situation which, if not avoided, may result in minor or moderate injury.



CAUTION

CAUTION used without the safety alert symbol indicates a potentially hazardous situation which, if not avoided, may result in property damage.

TD-24-T (5+20)

1.6 Uncaging Air Brakes

Air brakes are designed with a safety feature called a spring brake, so that if no air pressure is present in the system springs will apply force to the brake system linkages and apply the brakes. To allow the trailer to be moved during shipping a caging key is installed in each of the spring brake cans to prevent the brakes from being applied. These keys **MUST** be removed before the trailer can be put into service.



WARNING *INOPERATIVE BRAKE SYSTEM!*

The spring brake caging keys must be removed from the spring brake cans before the trailer is put into service. The brake system WILL NOT FUNCTION with the keys installed, and the trailer will roll freely until they are removed.

To remove the keys use the following procedure (see illustration on next page):

1. Hook up trailer to tow vehicle, and/or put air to the air brake system on the trailer.
2. Apply approximately 70 psi of air pressure to the brake system; this should be sufficient to remove the spring pressure and loosen the caging keys.
3. Hold the key and turn the washer behind it until the slots on the washer line up with the key.
4. Push the key in and turn it approximately 1/4 turn and pull out.
5. Cover the key hole with the attached rubber seal.
6. Repeat this procedure for all spring brake cans.

TD-24-T (5+20)

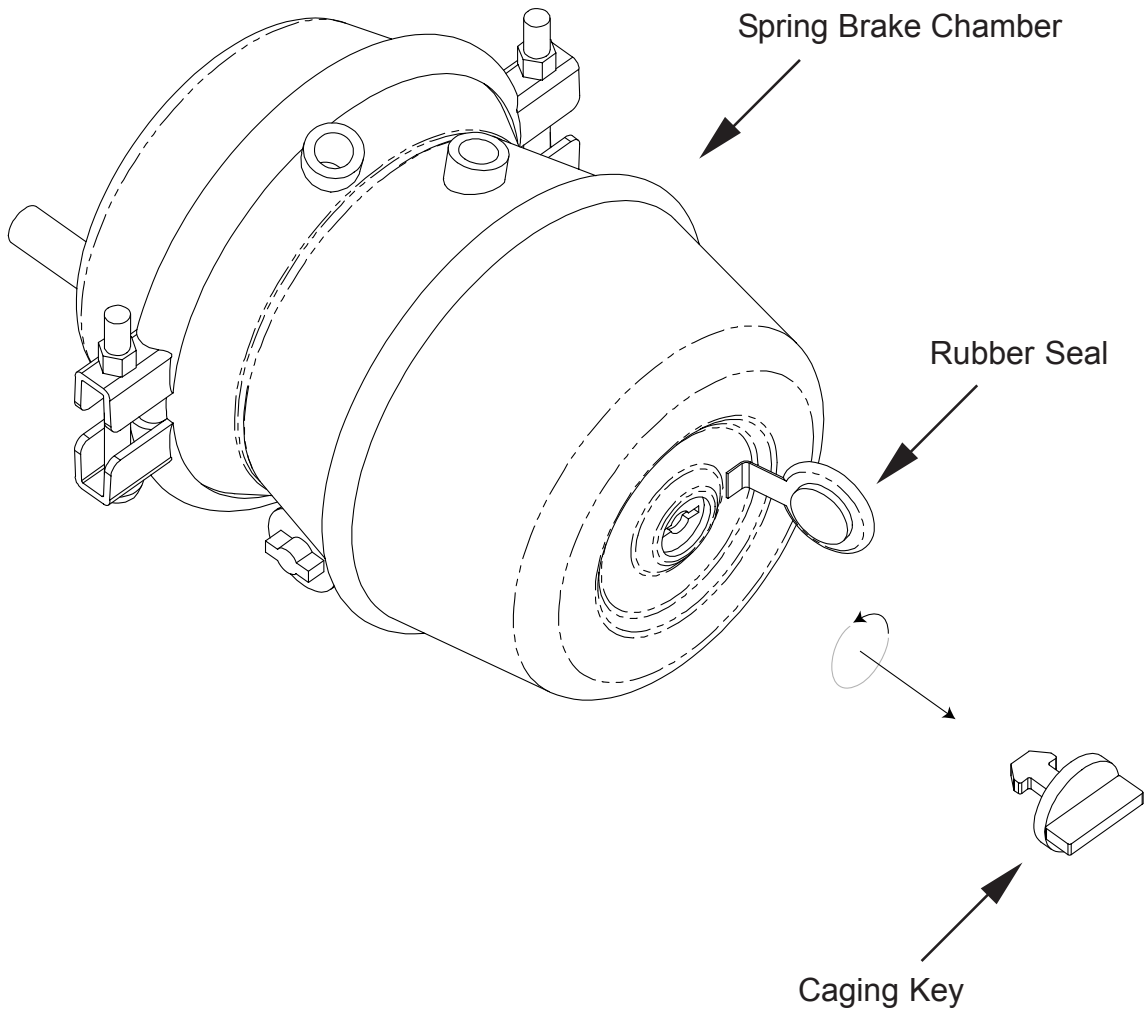

TD-24-T (5+20)

1.7 Reporting Safety Defects

If you believe that your vehicle has a defect that could cause a crash, injury, or death, you should immediately inform the National Highway Traffic Safety Administration (NHTSA) in addition to notifying Gem State Mfg., Inc.

If NHTSA receives similar complaints it may open an investigation, and if it finds that a safety defect exists in a group of vehicles it may pursue a remedy campaign and recall those vehicles. However, NHTSA cannot become involved in individual problems between you, your dealer, or Gem State Mfg., Inc.

To contact NHTSA, you may either call the Vehicle Safety Hotline toll free at 1-888-327-4236 (TTY: 1-800-424-9153), go to <http://www.safecar.gov>; or write to Administrator, NHTSA, 400 Seventh Street SW., Washington, DC 20590. You can also obtain other information about motor vehicle safety from <http://www.safecar.gov>.

1.8 Pre-Trip Inspection

There are some items on every vehicle combination that can be and should be inspected prior to every trip that require no special knowledge, training, or sophisticated equipment.

Before beginning a trip, make a thorough visual inspection of the trailer for cracks in the structure, or bent components such as the tongue or frame. Check for any missing fasteners in suspension as well as other areas, and look for broken or bent springs and spring hangers or otherwise damaged components.

Verify that the hitch on the tow vehicle is the correct size and configuration to fit the trailer coupling. The hitch must be rated to meet or exceed the Gross Vehicle Weight Rating (GVWR) of the trailer.

Check the hitch height of the trailer and compare it to the tow vehicle; it is very important that the trailer be towed in the level position when loaded. In order to achieve the correct hitch height, elevate the tongue of the trailer slightly (1" to 2") by adjusting the trailer hitch to compensate for settling of tow vehicle springs when loaded.

Always visually inspect hitch for unusual appearances such as bent components, cracks in welds or chipped paint where stress cracks may appear from high loads.

Check tires for proper inflation. Tire manufacturers recommend checking inflation pressure while trailer is not loaded and tires are cool. This will provide a more accurate reading. A drop of 10 PSI in tire pressure can reduce the carrying capacity of the tire as much as 20%. This reduced capacity could cause tire failure and poor tire life.

Maintaining proper wheel nut torque value is essential to prevent wheel end separation or potential damage to the hub or wheel. Always check wheel nuts every 50 to 100 miles for the first 200 miles of operation, then periodically thereafter. The same procedure should be repeated after dismount and remount of wheels. It is important to follow the specified tightening sequence recommended in the tire maintenance section of this manual.

TD-24-T (5+20)

1.9 Hook-Up Procedures

Connect the tow vehicle to the trailer and check that the coupler is completely latched. Be sure that a safety pin is inserted to ensure coupler will not unlatch during transport.

Connect the electrical plug from the trailer's harness to the receptacle of the tow vehicle. Check all lights on the trailer to make sure they are working correctly with the tow vehicle's electrical system.

Be sure the landing leg and drop foot are fully retracted and the crank handle is stowed in transport position. For trailers with 2-speed jacks, use low gear for raising and lowering the jack under load, and high gear for raising and lowering the leg when it is off the ground.

Check all safety chains and their attachment to both the trailer and the towing vehicle. Connect safety chains to tow vehicle using crossed pattern under tongue. Allow slack for turning, but avoid having chains drag on pavement. Make certain that all attachment devices are properly installed and in good working order.

For trailers with air brakes, connect the Glad Hands (one service and one emergency) to tow vehicle. Shut off petcock(s) on air tank(s) or if already shut, open to exhaust all moisture, then shut off. It is very important that the air system be drained of moisture after each use to keep all components functioning properly and to make equipment safe.

Trailers with electric brakes come equipped with an emergency breakaway device. The breakaway system is designed to operate after the coupling system has failed. Connect breakaway chain S-hook to bumper or hitch on tow vehicle. Allow slack for turning, but avoid letting the cable drag on pavement. Provide as straight a connection as possible.

The breakaway system is for emergencies and is not a parking brake.

1.10 Loading and Unloading

CAUTION

TRAILER LOADING PRACTICES

The consequences of ignoring proper trailer loading practices can be very serious. Failure to adhere to the information in this section could lead to unsafe handling, diminished braking capacity, or other unstable trailer characteristics which could result in an accident causing property damage, bodily injury or death.

It is the operators responsibility to take whatever steps necessary to load the trailer properly, even when it is not easy to calculate the total load or determine the load center of gravity.

A decal on the trailer similar to the one shown below indicates the correct placement of the load. Load the trailer so that 60% of the total load weight is forward of the arrow, and 40% is rearward of the arrow. This will ensure that the proper load balance and tongue weight are achieved.



CAUTION

ADVERSE WEATHER CONDITIONS!

Adverse weather conditions can cause wet and slippery trailer decks and ramps. Depending on the type of equipment and typical weather conditions it may be necessary to add traction aids to the trailer deck and ramps.

TD-24-T (5+20)

Always use extreme caution when loading and unloading equipment on trailer. Make sure road surface is level. Loading and unloading on an uneven surface may cause damage to the trailer frame and create unsafe loading conditions.

Always set brakes on tow vehicle and trailer before loading and unloading and use chock blocks as an added safety precaution.

Before securing equipment, always lower booms, loaders and buckets. The parking brake on the equipment being transported must be engaged, where applicable. Always make sure you are under the maximum allowable height clearance.

Equipment with crawler tracks as well as wheel type equipment should be restrained in the lateral, forward, rearward and vertical direction using a minimum of four direct tie-downs and binders each having a working load limit of at least 5000 lbs. and should be blocked to prevent forward movement.

Articulated vehicles shall be restrained in a manner that prevents articulation while in transit.

Trailers With Ramps

Loading ramps can be adjusted for various track widths. Prior to loading or unloading it is very important that ramps are adjusted to proper spacing for equipment being transported. When loading equipment onto deck, drive slowly forward until appropriate tongue load is achieved. Ramps are designed to support rear of trailer during loading and unloading. Ramps must be in stored position during transport.

Trailers With Tilt Decks

It is very important that the deck latch is in the locked position with the safety pin inserted at all times during transport. Always unlock deck when unloading equipment. Failure to do this may result in damage to deck. Deck latch is adjustable to keep deck tight and rattle free.

When loading equipment onto deck, drive slowly until deck begins to tilt closed, and proceed forward until 10% of load weight is on the hitch of trailer. Not enough tongue weight can result in swaying of trailer, which can be an unsafe condition.

When unloading use reverse procedure as loading. Back up slowly until deck begins to tilt, stop and wait for deck to completely open, then proceed to back off slowly.

Trailer deck will tilt open and tilt closed with one persons weight. The deck may tilt faster or slower depending on outside temperature, because the temperature affects the density of the fluid in the deck cylinder.

Section 2. Maintenance

2.0 Periodic Maintenance

New Trailer Break-in

- ✓ 50 to 100 miles- re-torque wheel nuts- see page 30.
- ✓ 1000 miles- check axle alignment and re-torque suspension fasteners- see page 20.

Pre-Trip Inspection

- ✓ Lube wear areas on hitch.
- ✓ Examine frame and tongue members for evidence of damage or cracked welds.
- ✓ Check suspension for bent or broken springs, damaged components, and loose or missing fasteners.
- ✓ Check wheel hub oil levels and for evidence of leaking wheel seals.
- ✓ Check tire inflation pressures- see page 31.
- ✓ Check hitch for damage or stress and verify correct hitch height.
- ✓ Check lights for correct operation.

Quarterly or 3000 miles

- ✓ Check wheel nut torques- see page 30.
- ✓ Check brakes for adjustment- air brakes see page 34; electric brakes see page 46.

Semi-Annually or 6000 miles

- ✓ Lubricate jack- see page 17.
- ✓ Re-torque suspension fasteners- see page 20.
- ✓ Inspect and lubricate brakes and linings- air brakes see page 34, electric brakes see page 38.
- ✓ Lubricate tilt deck hinges- see page 17.
- ✓ Replace wheel bearing lubricant (heavy duty/off-road service)- see page 26.

Annually or 12,000 miles

- ✓ Replace wheel bearing lubricant (standard duty service)- see page 26.

Special-

- ✓ Accident or Overload- check all structural components for damage. Check tires and wheels for damage. Check axle alignment.
- ✓ Rear Impact- check impact guard components for damage- see page 18.
- ✓ Skidding- check tires for flat spots.

TD-24-T (5+20)

2.1 Structural Components

Sub-Frame

Other than for periodic or special inspections the trailer sub-frame requires no regular maintenance other than washing. Keeping the trailer clean will help you notice other things such as cracked welds or corrosion. If your application requires the hauling of corrosives then frequent washdowns are very important.

Deck

The deck is the major load-carrying member of the trailer. It requires no regular maintenance other than a periodic check for broken welds, loose fasteners and corrosion. If the trailer has been overloaded or in an accident, inspect the deck carefully.

It may be necessary to apply a new coat of wood preservative after decking has aged and become dry. The best time to apply preservative is during warm weather for better penetration. Replace decking when necessary. Occasionally check for loose, missing, or broken deck screws.

2.2 Sub-Assembly Components

Drawbar Eye

Check the eye for cracks, loose fasteners and wear. Regularly apply a coating of grease to the eye to prevent accelerated wear.

The fasteners for the drawbar eye are very important and deserve careful attention. Replace the bolts if they are damaged in any way, and replace the locknuts if worn. Torque the fasteners to 315 to 420 lbs.-ft.

Binkley Jack

Every six months, lubricate the jack in the following manner:

1. Extend the leg approximately 2 inches from the fully retracted position.
2. Add 1/4 pound molybdenum grease (with a temperature rating suitable for your operating conditions) to each of the grease fittings.

The following three sub-sections pertain to trailers with tilt decks-

Cushion Cylinder

The fluid in the cylinder should be changed if the cylinder has leaked or if the deck action has become jerky or sluggish. Fully collapse the cylinder, and then remove the filler plug and drain out the old fluid. Add 10W hydraulic fluid until the cylinder is full and all the air has been expelled.

Deck Latch

The latch assembly is designed with replaceable, self-lubricating bushings at the wear points. See the appropriate pages of the Parts section of this manual for further information.

Should the deck develop a rattle, adjust the hook receiver assembly on the tilt deck.

Deck Hinge Assembly

The hinge assembly is highly stressed during loading and unloading, so check it for cracked welds frequently.

Every six months, or sooner if service dictates, grease the deck hinges. Apply grease to the fittings (one per side) until fresh grease becomes visible.

TD-24-T (5+20)

2.3 Rear Impact Guard (RIG)

Your trailer may be fitted with an energy absorbing RIG system that retracts automatically when the deck is tilted for loading and unloading. An elastomeric torsion block assembly is part of the system and absorbs the excess travel of the retraction hardware. Normally the RIG requires no maintenance other than checking for loose fasteners or missing cotter pins.

In the event of a rear impact to the trailer, check the RIG system thoroughly for bent or damaged components. There are two sacrificial elements in the system called crush blocks that are intended to deform while absorbing the forces of an impact. If they show any signs of deformity from having been impacted by the RIG pivot arms, they should be replaced immediately. In no case should the crush blocks be 'straightened' or repaired in any way; they both must be REPLACED if deformed by the RIG pivot arms. Also check the deck beam flanges that the crush blocks bolt to for damage or bending. The flanges may have to be straightened if the impact was particularly severe.

Other areas to check include cracked welds, damaged lighting or electrical harness, bent hinge tube or hinge pin, bent retraction push rod, and bent or broken pivot pins and fasteners. If, after impact, the RIG does not hang normally from the trailer deck and no other damage can be found, it is possible that the torsion block assembly has been overstressed and should be inspected and replaced if necessary.

As a last check, tilt the deck while observing the RIG and make sure that it retracts and extends normally.

2.4 Running Gear

Suspension

The suspension on your trailer is a heavy duty, leaf spring, underslung type. An eye is formed into the forward end of the longest leaf spring, while the aft end is free to float against the wear pads of the hangers and rockers. Adjustable spring seats are employed to keep the axles in alignment.

The first maintenance check should be performed after an initial break-in period of about 1,000 miles. A visual inspection of all suspension components and attachment welds should be performed to reveal any obvious problems, such as cracks or unexpected wear.

During this 'walk-around', it is essential to also check the torque on all suspension fasteners. In the course of the initial 'shake down' period in which the components of the suspension system 'seat in', as much as 25% of the original clamp load on the bolted joints can be lost. After the parts of the suspension have worked together for a very short period of time, re-torquing the bolts is necessary to insure that undue movement, which results in excessive suspension wear, does not occur.

During the first maintenance check, the trailers axle alignment should be examined and adjusted. Alignment should also be checked following any maintenance or repair procedure performed on the suspension.

Visually inspect the suspension system every three months or 25,000 miles for signs of excess wear, elongation of bolt holes, and loosening of fasteners. Whenever loose or replaced the fasteners in your suspension system should be torqued as detailed below. It is important that you check all bolts and nuts to insure that the recommended torque values are being maintained.

You cannot ascertain these torques values visually or by 'feel'. USE A TORQUE WRENCH!

TD-24-T (5+20)

⚠ WARNING TORQUE REQUIREMENTS!

Follow all torque requirements! Do not use any component with visibly worn or damaged threads. Failure to follow these safety alerts can lead to loss of vehicle control, property damage, serious personal injury or death.

| Ref. | Item | Torque |
|------|----------------------------------|-----------------|
| 1. | Keeper Bolt | 35-45 lb.-ft. |
| 2. | Equalizer Bolt | 350-400 lb.-ft. |
| 3. | Spring Eye Bolt | 275-325 lb.-ft. |
| 4. | $\frac{5}{8}$ " diameter U-bolts | 110-130 lb.-ft. |
| 4. | $\frac{3}{4}$ " diameter U-bolts | 130-170 lb.-ft. |

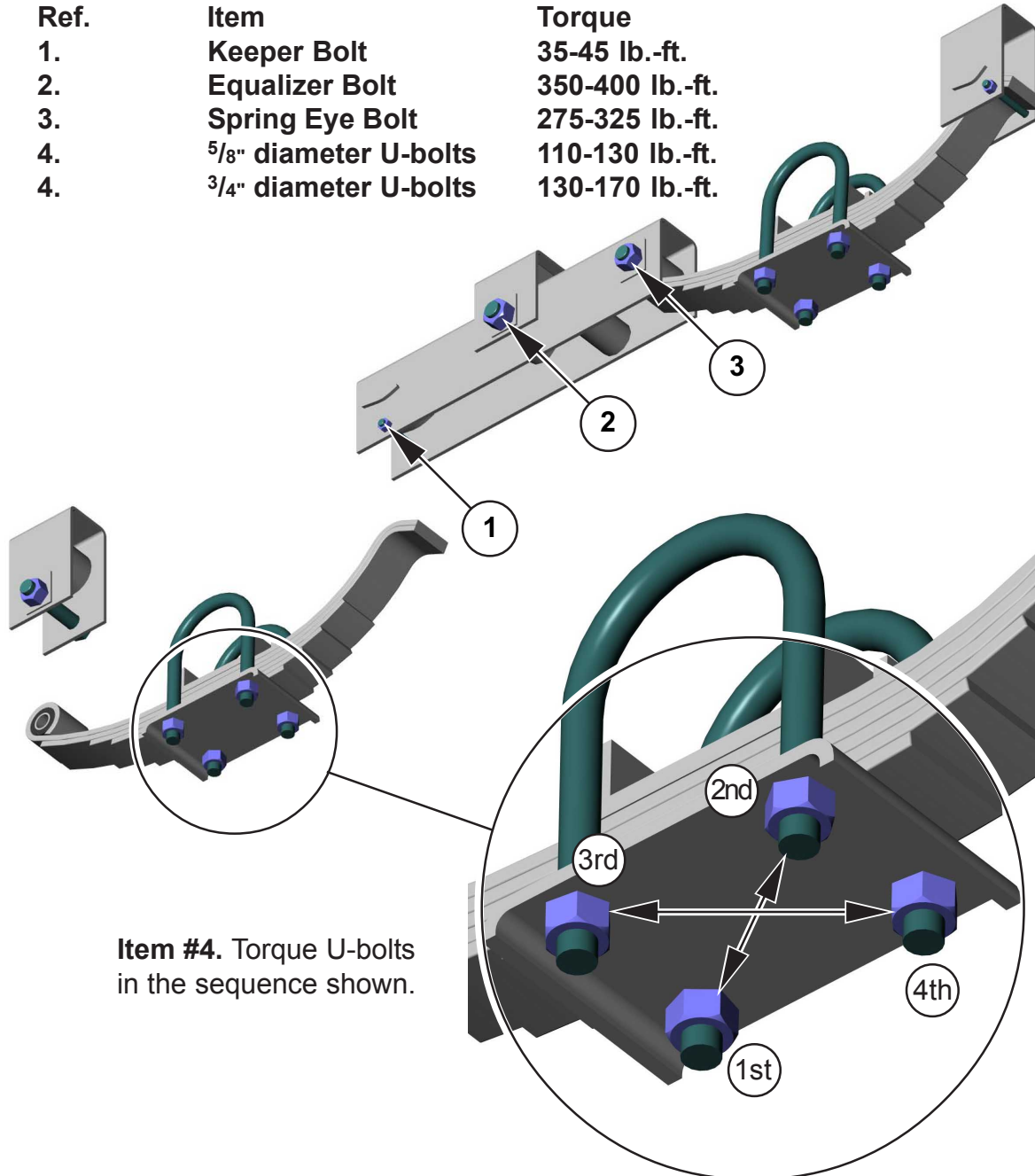

Item #4. Torque U-bolts in the sequence shown.

TD-24-T (5+20)

Axle Alignment

Verify that the forward axle is centered on the trailer; $W_1 = W_2$. Check the distance from the hitch center to the forward axle end on both sides, and adjust the spring seat adjusters if necessary so that X_1 is $1/8$ " less than X_2 . Next check the W and Z distances for the second axle, and then do the same for the third axle, if so equipped. Try to hold the measurements to within $\pm 1/16$ ".

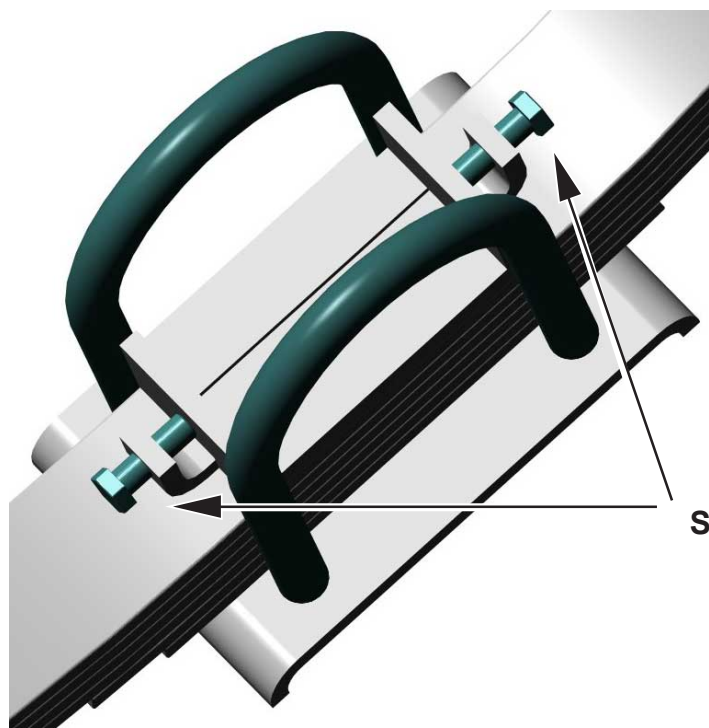
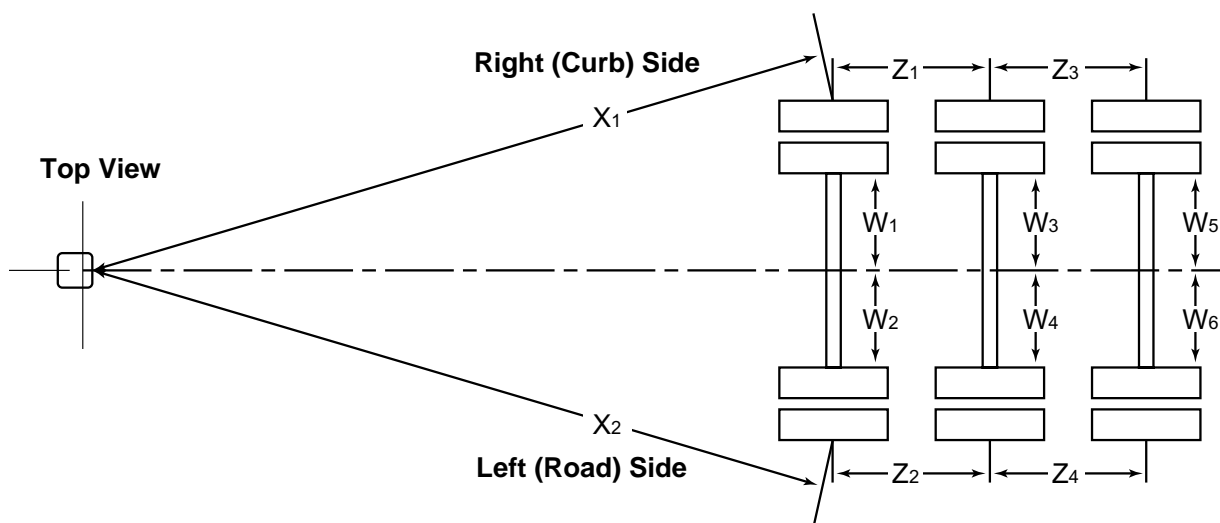

MAINTENANCE

TD-24-T (5+20)

Hub and Drums

Hub Removal- Whenever the hub equipment on your trailer must be removed for inspection or maintenance the following procedure should be utilized:

1. Jack up the wheel. Use a jack stand to support the axle. Only right hand thread wheel nuts and studs are used on your trailer.
2. Unscrew the polycarbonate oil cap. Have a clean container under the axle to catch the escaping oil. Examine the oil for evidence of metal particles or foreign matter.
3. Remove the outer jam nut.
4. Remove the lock washer.
5. Remove the inner spindle nut.
6. Remove the hub from the spindle, being careful not to allow the outer bearing cone to fall out. The inner bearing cone should be retained by the oil seal.

Hub Inspection

Clean the hub with a commercial solvent for inspection. Check for cracks, elongated holes, evidence of overheating or foreign object damage. The hub is crucial to safe vehicle operation and any doubt about its condition should be cause for replacement.

Broken or Damaged Studs

Typically when a stud is damaged it is due to under torque (loose wheel nuts), over torque, or overloading. Because the studs act together to share the wheel loads, these parameters must be followed:

1. If one stud is broken, replace the studs on either side of the broken one also.
2. If two or more studs are broken, replace the entire set.
3. A stud with damaged threads should be replaced immediately.

Brake Drum Inspection

Clean and inspect the brake drums whenever relining the brakes. To be suitable for further service, the brake drum should pass the following checks:

1. The brake surface should be free of scoring, excessive heat checks and free of cracks.
2. The brake surface diameter should be within the maximum diameter stamped on the drum.
3. The mounting holes and pilot must be round and true.
4. The mounting surface must be clean and flat.



WARNING

BRAKE SYSTEM SAFETY!

If any of the above conditions are not met, the brake drum should be replaced. Failure to replace the brake drum will result in an unreliable braking system, and may lead to an accident.

It may be desirable to machine the braking surface to remove small heat checks or other surface defects resulting from normal use. The following should be noted when turning the brake drum:

1. The maximum diameter cast into the back plate portion of the brake drum is the discard diameter. If any portion of the brake drum exceeds the maximum diameter it must be replaced.
2. When preparing to machine a drum, allow at least .040" under the maximum diameter for further normal in-service wear. Failure to allow for service wear will result in a weakened brake drum and may result in an accident.

Brake drums should be replaced in pairs to achieve the same braking power on both wheels and maintain even braking load on the axle. Failure to replace both brake drums on an axle will result in uneven braking load on the axle and may significantly reduce the performance, service life and/or safety of your vehicle.

See the brake drum troubleshooting charts on the following pages for more information.

TD-24-T (5+20)

Brake Drum Troubleshooting Chart

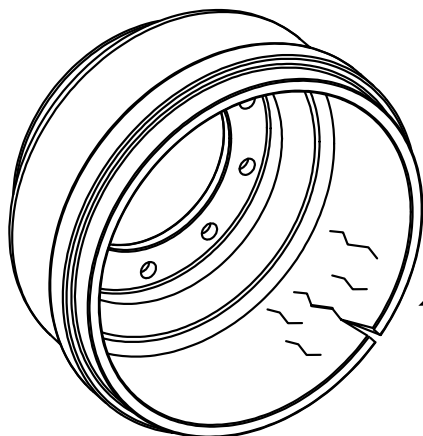
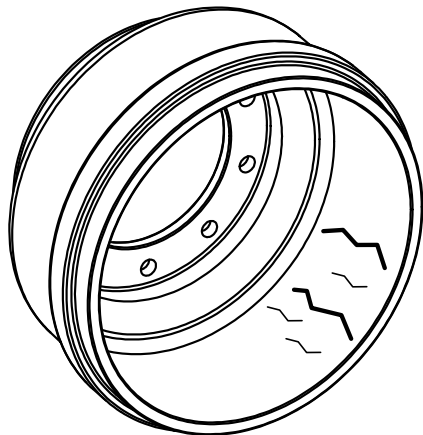
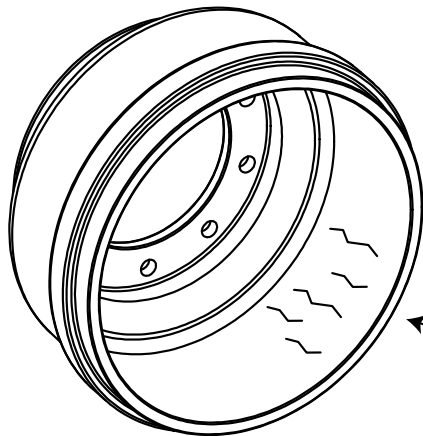

| PROBLEM | CAUSE | REMEDY |
|------------------------------------|---------------------------------------------------------------------------------------------------------------------|------------------------------------------------------------------------------------------------------------------------------|
| OIL STAINED DRUMS | LEAKING SEAL | REPLACE SEAL. CLEAN DRUMS & REPLACE LININGS. |
| LIGHT HEAT CHECK | NORMAL CONDITION | MACHINE |
| BLUE OR DISCOLORED BRAKE SURFACE | EXCESSIVE HEAT FROM DRAGGING BRAKES OR BRAKE IMBALANCE BETWEEN TRACTOR AND TRAILER | MACHINE BRAKE DRUM. CHECK RETURN SPRINGS AND FOR BINDING BRAKE ACTUATION SYSTEM. |
| POLISHED BRAKE SURFACE | NON-ASBESTOS LINING | NORMAL CONDITION |
| | IMPROPERLY CURED BRAKE LINING | MACHINE OR DE-GLAZE WITH EMERY CLOTH |
| HEAVY HEAT CHECK | IMBALANCED BRAKE SYSTEM, DRAGGING BRAKES, OR DRIVER ABUSE. CAUSED BY CONSTANT HEATING AND COOLING OF BRAKE SURFACE. | REPLACE BRAKE DRUM. CHECK BRAKE BALANCE, BRAKE RETURN SPRINGS, BRAKE ADJUSTMENT, AND LINING TYPE WITHIN VEHICLE COMBINATION. |
| NOISE, CHATTER, OR PULSATING BRAKE | HEAT SPOTTED, GREASE STAINED, OR OUT OF ROUND DRUM OR LOOSE BRAKE COMPONENTS | CHECK BRAKE DRUM FOR FAULTY CONDITION AND REMEDY AS DESCRIBED IN THIS SECTION |
| FADING OR WEAK BRAKE | HIGH TEMPERATURES IN BRAKE SYSTEM, IMPROPER ADJUSTMENT, OR INFERIOR LINING. | CHECK BRAKE DRUM, LINING CONDITION, AND BRAKE BALANCE. AVOID CONDITIONS OR LOADS WHICH CREATE HIGH BRAKE TEMPERATURES. |
| | MISHANDLING | REPLACE |
| CRACKED BRAKE DRUM | HEAT CHECKS GROW AND JOIN TOGETHER THROUGH DRUM SECTION | REPLACE BRAKE DRUM. CHECK BRAKE BALANCE, BRAKE RETURN SPRINGS, BRAKE ADJUSTMENT, AND LINING TYPE WITHIN VEHICLE COMBINATION. |
| | IMPROPER SHOE CONTACT | REPLACE. CHECK SHOE CONTACT AREA. |

TD-24-T (5+20)

Brake Drum Troubleshooting Chart (continued)

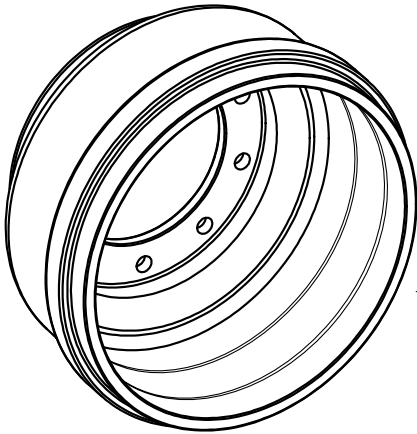

| PROBLEM | CAUSE | REMEDY |
|---------------------------------------------|----------------------------------------------------------|------------------------------------------------------|
| FINE GROOVES | ABRASIVE FOREIGN MATERIAL OR POOR QUALITY BRAKE LINING | MACHINE OR REPLACE BRAKE DRUM AND REPLACE LINING |
| | LOOSE RIVETS OR BOLTS OR FOREIGN MATERIAL IN RIVET HOLES | MACHINE OR REPLACE BRAKE DRUM. USE RIVET HOLE PLUGS. |
| HEAT SPOTTED OR HARD SPOTS IN BRAKE SURFACE | HIGH LOCALIZED HEATING AND COOLING CYCLES | GRIND HARD SPOT AND MACHINE DRUM |

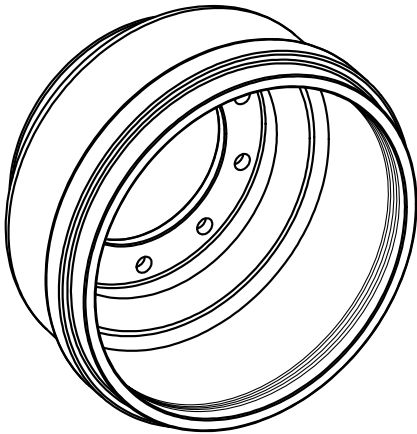

| | | |
|-----------------------------------------------------|--------------------------------------------------------|--------------------------------------------------------------|
| EXCESSIVE WEAR | ABRASIVE FOREIGN MATERIAL OR POOR QUALITY BRAKE LINING | MACHINE OR REPLACE |
| MOUNTING FLANGE SEPARATED FROM HOOP SECTION OF DRUM | INSTALLATION ON DIRTY HUB | REPLACE DRUM. CLEAN THE HUB PRIOR TO INSTALLING NEW DRUM. |
| | WHEEL HITTING BRAKE DRUM | INCORRECT APPLICATION. REPLACE BRAKE DRUM WITH CORRECT PART. |

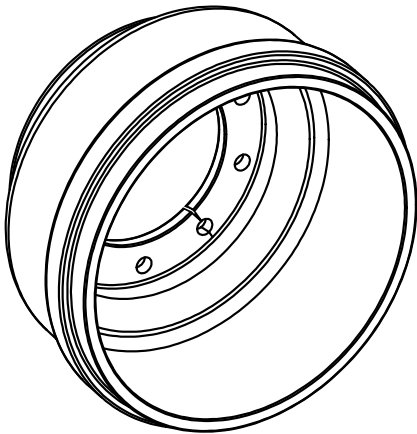

| | | |
|----------------------------------------|-----------------------------------------------------------|-----------------------------------------------------------------|
| GROOVES ALONG EDGES OF LINING | ABRASIVE MATERIAL COLLECTING ALONG EDGES OF LINING | DUST SHIELD MAY CAUSE OR CURE THIS. MACHINE BRAKE DRUM. |
| OUT OF ROUND: CONCENTRICITY | IMPROPER FIT TO PILOT OR IMPROPER SEATING ON WHEEL OR HUB | MACHINE OR REPLACE. CHECK FOR CORRECT FIT & CLEARANCE TO WHEEL. |
| OUT OF ROUND: VARIATION IN DIAMETER | HEAT DISTORTION | MACHINE OR REPLACE |
| OUT OF ROUND: BALANCE | BALANCE WEIGHT FALLEN OFF OR NOT A BALANCED DRUM | REPLACE. SPECIFY BALANCED DRUM WHEN ORDERING REPLACEMENT |
| CRACK BETWEEN PILOT HOLE AND BOLT HOLE | MISHANDLING | REPLACE |
| | INSTALLATION ON DIRTY HUB | REPLACE. CLEAN HUB BEFORE INSTALLATION. |

MAINTENANCE

TD-24-T (5+20)

Bearing Inspection

Wash all grease and oil from the bearing cone using a suitable solvent. Dry the bearing with compressed air or a lint-free cloth and inspect each roller completely. Also clean and inspect the cups (races) inside the hub. Any pitting, spalling, bluing (heat damage) or corrosion is cause for replacement.

NOTE: Bearings must always be replaced in sets of a cone and cup.

⚠ CAUTION *RISK OF PERSONAL INJURY!*

Be sure to wear safety glasses when performing the following procedure. Failure to do so can result in serious injury.

To remove the bearing cup from the hub, proceed as follows:

1. Place the hub on a flat work surface with the cup to be removed on the bottom side.
2. Using a brass drift punch, carefully tap around the small diameter end of the cup to drive it out.
3. After cleaning the hub bore area, tap in the new cup with the brass drift. Work gently around the perimeter of the cup so as not to distort it. Make sure that it is fully seated against the retaining shoulder in the hub.

Bearing Lubrication

Wheel end lubricant should be replaced periodically as described earlier in this section. Follow these guidelines for lubricant replacement:

1. If possible, wash down the area around the wheel end thoroughly.
1. Place a clean container under the axle cap.
2. Loosen and remove the oil drain plug. Allow the old lubricant to drain out completely. Examine this oil for particles or contamination that might warrant further component examination.

3. Reinstall the drain plug.

4. Remove the fill plug on the axle cap and add oil to the line on the cap. Reinstall the plug and check for leaks.

Use a gear oil of API GL-5 performance level. SAE 90 weight oil is normally preferred for most operating environments. Other approved oil weights are SAE 80W-90, SAE 80W-85W-90, and SAE 75W-90.

Seal Inspection and Replacement

Whenever the hub is removed, inspect the seal to assure that it is not nicked or torn and is still capable of properly sealing the bearing cavity. If there is any question of its condition, replace the seal. To replace the seal:

1. Pry the old seal out of the hub with a screwdriver. Be careful not to scratch or nick the sealing surface of the hub with the end of the screwdriver.

2. Clean the hub surfaces. If the bearing is removed for any reason, be sure to reinstall it before pressing in the new seal. Apply a Permatex sealant to the outside of the new seal (metal seal shells only).

3. Tap the seal into place using a clean wood block.

Hub Reinstallation and Bearing Adjustment

The objective of this procedure is to attain 0.001" to 0.010" end play.

1. Place the hub (with inner bearing set and oil seal installed), outer bearing and adjusting nut (inner spindle nut) back on the spindle in the reverse order of removal. Rotate the hub assembly in both directions while tightening the adjusting nut to approximately 100 lbs.-ft. of torque.

2. Loosen nut to remove preload torque without rotating hub.

3. Hand tighten nut then back off $\frac{1}{8}$ turn minimum, $\frac{1}{4}$ turn maximum.

4. Install tab washer and outer nut. Torque outer nut to 225 to 250 lb.-ft. Insure that the inner nut does not turn.

5. Bend 2 tabs over outer nut to secure in place.

TD-24-T (5+20)

2.5 Wheels and Tires

Wheels

Wheels are a very important and critical component of your running gear. Inspect them visually for cracks or elongated bolt holes whenever they are removed for any reason. If it becomes necessary to replace the wheels on your trailer, be certain that the replacement units match the originals in the following regards:

1. Type. The disc wheels and hubs on your trailer are of the hub piloted design.
2. Material. Do not mix aluminum and steel disc wheels or aluminum and steel disc wheel capnuts. This may result in incorrect components being used to secure the wheels, which can lead to loose wheels resulting in a crash.
3. Fit. Use only the correct matched parts when mounting disc wheels. Incorrect components can result in separation of the rim components.
4. Bolt Circle. Many bolt circle dimensions are available and some vary by so little that it might be possible to attach an improper wheel that does not match the axle hub. Be sure to match your wheel to the axle hub.
5. Capacity. Be sure your wheels have enough load carrying capacity and pressure rating to match the maximum load of the tire and trailer.
6. Offset. This refers to the relationship of the center line of the tire to the hub face of the axle. Care should be taken to match a replacement wheel with the same offset wheel as originally equipped. Failure to match offset can result in reduced carrying capacity of your axle.

7. Rim Contour.

⚠ WARNING

RIM CONTOURS!

Use only the approved rim contours as shown in the Tire and Rim Yearbook or the tire manufacturers catalog. The use of other rim contours is dangerous. Failure to use the proper rim contour can result in explosive separation of the tire and wheel and could cause a serious accident.

⚠ DANGER

WHEEL MODIFICATIONS!

Do not attempt to repair or modify a wheel. Even minor modifications can have a great effect. Do not install a tube to correct a leak through the rim. If the rim is cracked, the air pressure in the tube may cause the pieces of the rim to explode with great force and can cause serious injury or death.

It is imperative for the safety and life of your vehicle that disc wheels and tire assemblies be correctly installed and fasteners properly torqued. To assure proper installation, adhere to the following parameters:

Do not use heat to remove wheel nuts. If heat is used to remove a nut, the stud, nut, and outer wheel must be replaced.

Insure that you are using the correct wheel nuts for your wheels. Failure to do so may lead to loose wheels and wheel damage, and may result in a crash.

TD-24-T (5+20)

Wheel Torquing Procedures

When installing the wheels, make sure that the hub and wheel mating surfaces are clean and free of rust, dirt and excess paint. The studs and threads must be clean, dry and in good condition for applying installation torque.

The hand torque wrench or air wrench used to install the wheels must be periodically calibrated to insure proper applied torque. Adjust the tools as necessary.

Position the inner disc wheel over the studs, being careful not to damage the stud threads. Make sure the disc wheel is flat against the mounting surface and there is clearance between the disc wheel taper and the brake drum.

Position the outer disc wheel against the inner wheel being careful not to damage the threads on the studs. Be sure the valve stems for both the inner and outer tires are accessible.

Install the wheel nuts and tighten to a partial torque of 50 lbs.-ft. using the sequence shown, and then tighten them to a full torque of 200 lbs.-ft. in sequence.

For both new installations and reinstallations, the parts will seat naturally and the torque will drop after the first 50 to 100 miles of operation. Retighten the wheel nuts to proper torque at this interval using the sequence above.

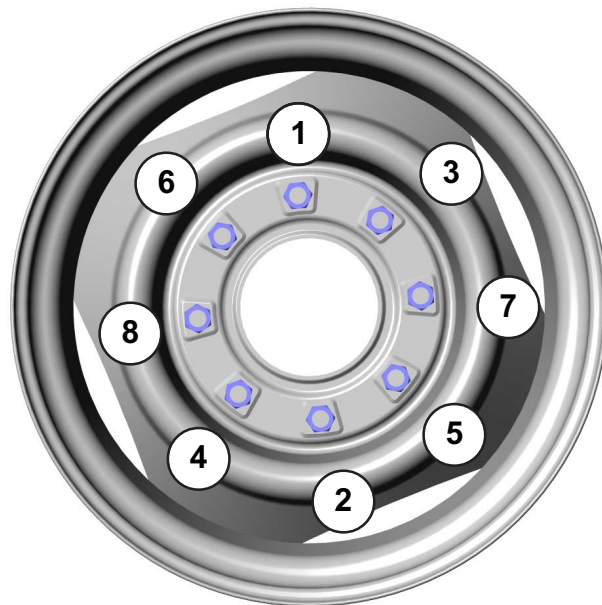

Tires

Before mounting tires onto wheels make certain that the rim size and contour is approved for the tire as shown in the Tire and Rim Association Yearbook or the tire manufacturers catalog. Also make sure the tire will carry the rated load. If the load is not equal on all tires due to trailer weight distribution, use the tire rated for the heaviest wheel position.

All tires must be matched to within $\frac{3}{4}$ " of the same rolling circumference per the tire manufacturers instructions. Do not use tires that fail to meet this criterion. Doing so may result in unstable operation and significantly reduced service life.

Use tire mounting procedures as outlined by the Rubber Manufacturers Association or the tire manufacturer.





Inflation Pressure

Correct tire inflation pressure for the LT245/75R 16 tires is 80 psi and is the most important factor in tire life. Inflation pressure should be as recommended by the manufacturer for the load. Pressure should be checked cold before operation. Do not bleed air from tires when they are hot. Check inflation pressure weekly during use to insure the maximum tire life and tread wear. Use the tire wear diagnostic chart to help you pinpoint the causes and solutions of tire wear problems.

NOTE: Tire wear should be checked frequently because once a wear pattern becomes firmly established in a tire it is difficult to stop, even if the underlying cause is corrected.

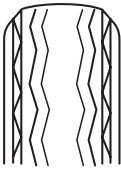
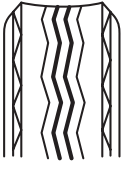
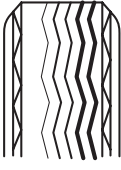
TD-24-T (5+20)

Tire Wear Diagnostic Chart

| | Wear Pattern | Cause | Corrective Action |
|-------------------------------------------------------------------------------------|---------------------|---------------------------------|-----------------------------------------------------|
|  | Center Wear | Over inflation | Adjust pressure to particular load per tire catalog |
|  | Edge Wear | Under inflation | Adjust pressure to particular load per tire catalog |
|  | Side Wear | Loss of camber or over loading | Adhere to load limits. Have axle aligned |
|  | Toe Wear | Incorrect toe-in | Have axle aligned |
|  | Cupping | Loose bearing or out of balance | Adjust bearing; balance tires |
|  | Flat spots | Wheel lockup or tire skidding | Adjust brakes; avoid sudden stops |

2.6 Electrical

Harnesses and Lights

The electrical harnesses in the trailer run within the frame members and require no maintenance. The oval stop/turn/tail lights and the round clearance lights are all of the sealed type and do not have a separately replaceable bulb. If a light stops working, first check the plug at the light for voltage (with a test lamp or volt meter) to verify that the electrical system is functioning properly. If it is then replace the lamp; if not then troubleshoot the electrical system.

Junction Block

The junction block requires no regular maintenance. If an electrical problem develops, check for corroded or loose terminals.

Seven-Way Plug

The plug should be kept clean and free of dirt. If an electrical problem develops, loosen the plug cover retaining screw, slide the cover down over the harness, and check the screws that hold the wires for security. Also check for stray or broken strands of wire.

TD-24-T (5+20)

2.7 Air Brake System

The following section applies if you have chosen an air brake system on your trailer. The front axles have brake cylinders with spring brake chambers. Vehicle safety is enhanced through the use of an Anti-Lock Braking System (ABS) that controls the brakes on the front axle. Automatic slack adjusters are used so that optimal braking effectiveness is maintained throughout the life of the linings.

CAUTION

ASBESTOS DUST HAZARD!

Since some brake shoe friction materials contain asbestos, certain precautions need to be taken when servicing brakes:

- 1. Avoid creating or breathing dust.*
- 2. Avoid machining, filing or grinding the brake linings.*
- 3. Do not use compressed air or dry brushing for cleaning.
(Dust can be removed with a damp brush.)*

CAUTION

RISK OF PERSONAL INJURY!

Whenever it becomes necessary to jack the trailer it is up to you to ensure that the trailer or axle is supported securely. Use blocks or jack stands on solid ground, especially if you are going to be working under the trailer.

General Air Brake Maintenance

Camshaft Bushings

Lubricate with NLGI Grade 2 grease through the grease zerks at the spider and camshaft support bracket locations. Apply just enough grease so grease is visible flowing past camshaft bushing seals. During this process it is advisable to grab the camshaft and shake the camshaft to see if there is excessive clearance in the camshaft bushings due to wear.

Camshaft Roller Journals and Brake Anchor Pins

These components are to be lubricated with a high-temperature anti-seize grease upon disassembly, maintenance and reassembly.

Automatic Slack Adjuster Maintenance

1. Check the condition of the foundation brakes, including drums, shoes and linings, cams, rollers, bushings, etc.
2. Check for structural damage of the housing, worn clevis, worn clevis bushings and condition of the boots for cuts or tears. Replace if necessary.
3. After allowing the brake drums to cool to room temperature, check for correct chamber stroke as follows:
 - a. Measure the applied stroke. Using a ruler, measure the distance from the face of the air chamber to the center of the large pin in the clevis. Make an 85 psi brake application and allow the chamber pushrod to travel to its maximum stroke. Again, measure the distance from the face of the chamber to the center of the large pin. The applied stroke is the difference between the two measurements. For the Type 16 chamber the applied stroke specification is 1-1/2"; for the Type 24 chamber, the stroke specification is 1-3/4". (The chamber type number is stamped on the chamber itself). If this distance is less than specified, then the slack adjuster is functioning properly. If the applied stroke is more than specified, proceed with step b.

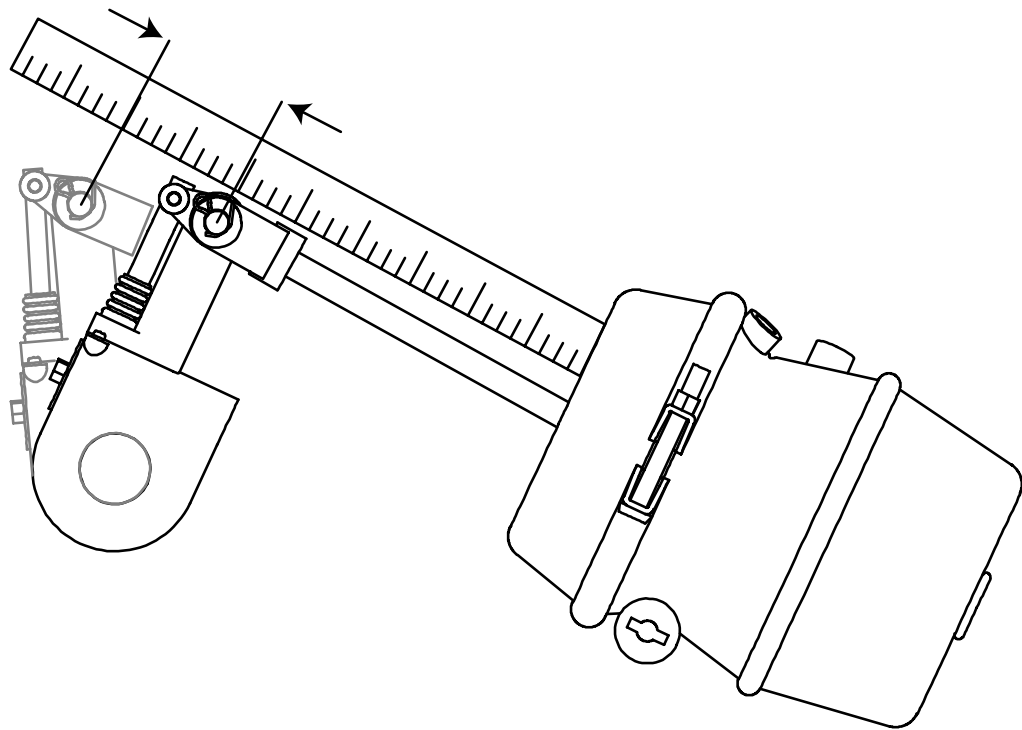

TD-24-T (5+20)

b. Measure the free stroke. Make the same two measurements as described above for measuring the applied stroke, but instead of air pressure use a lever to move the slack adjuster arm until the brake shoes contact the drum. This distance should be between $\frac{3}{8}$ " to $\frac{5}{8}$ ".

If the free stroke is good but the applied stroke is too long then there is a problem with the foundation brake. Check the foundation brake for missing or worn components, cracked brake drums, or improper lining to drum contact.

If the free stroke is less than $\frac{3}{8}$ ", then a dragging brake can occur. Readjust the slack adjuster manually as described below.

If the applied stroke is good but the free stroke is greater than the recommended distance ($\frac{3}{8}$ " to $\frac{5}{8}$ "), then a function test of the slack adjuster should be performed as described below.

Manual Brake Adjustment

1. Rotate the hex extension clockwise until the brake linings contact the brake drum, then back off the slack adjuster by rotating the hex extension counterclockwise $\frac{1}{2}$ turn. Backing off the slack will require about 25 to 30 lbs.-ft. of torque, and a ratcheting sound will be heard.

Slack Adjuster Function Test

1. Rotate the slack adjuster hex extension $\frac{3}{4}$ turn counterclockwise (you should need to apply 25 to 30 lbs.-ft. of torque, and a ratcheting sound will be noted). Mark the hex extension with chalk and then apply the brakes several times and watch for the hex to rotate clockwise. The adjuster is designed to move in small increments so it will take several brake applications to bring the adjuster to the fully adjusted position.

2. If the hex extension did not rotate clockwise or it took less than 15 lbs.-ft. of torque to rotate the hex extension then the slack adjuster must be replaced. If an immediate replacement part is not available, then the brakes must be kept in adjustment manually until a new slack adjuster can be installed.

3. If the hex extension rotates clockwise with repeated brake applications and the torque required to rotate the hex extension manually counterclockwise is greater than 15 lbs.-ft., then the slack adjuster is functioning properly. If you were performing this function test because of improper stroke measurements, then you need to examine the foundation brake for the source of trouble.

4. Readjust the brake after the function test.

TD-24-T (5+20)

2.8 Electric Brake System

Operation

The electric brakes on your trailer are similar to the drums brakes on your automobile. The basic difference is that your automotive brakes are actuated by hydraulic pressure while the electric brakes are actuated by an electromagnet. With all of the brake components connected into the system, the brake will operate as follows:

1. When the electrical current is fed into the system by the controller, it flows through the electromagnets in the brakes. The high capacity electromagnets are energized and are attracted to the rotating armature surface of the drums which moves the actuating levers in the direction that the drums are turning.

2. The resulting force causes the actuating cam block at the shoe end of the lever to push the primary shoe out against the inside surface of the brake drum. The force generated by the primary shoe acting through the adjuster link then moves the secondary shoe out into contact with the brake drum.

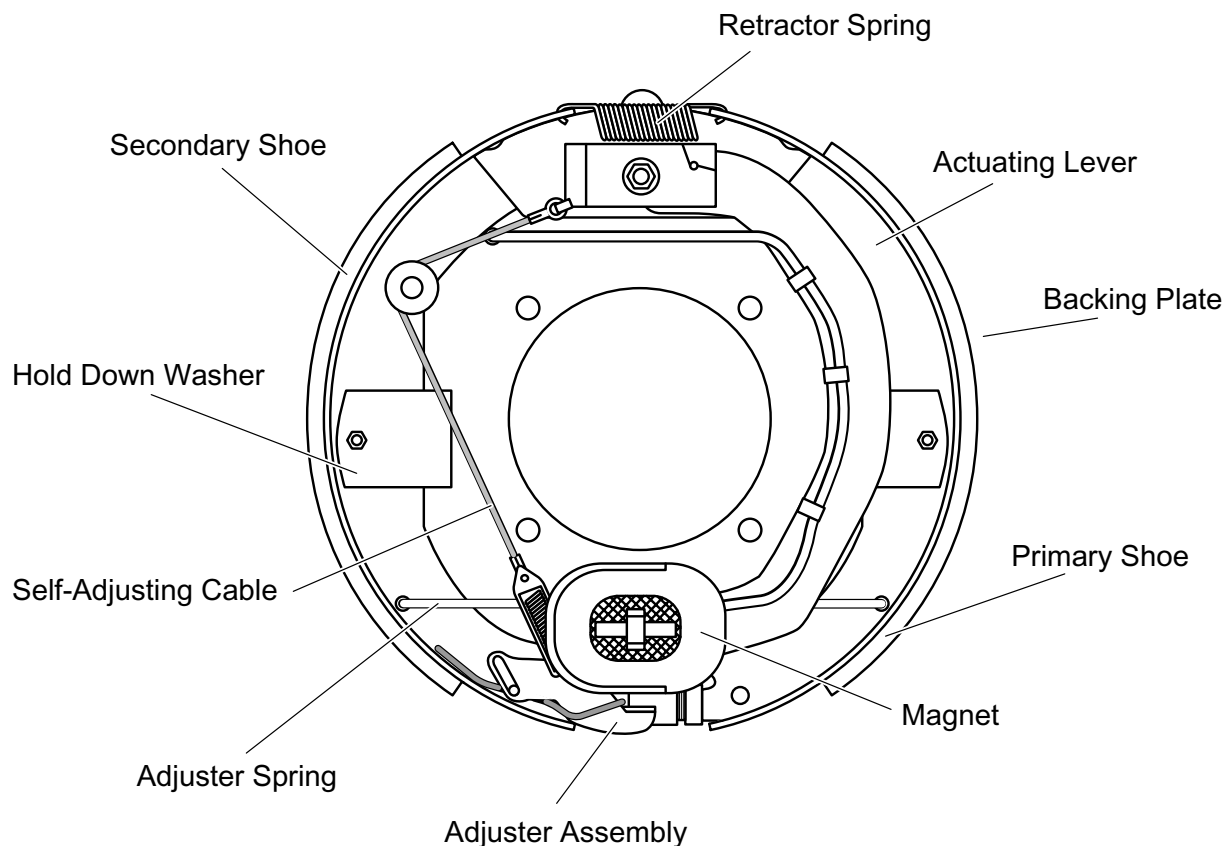

Increasing the current flow to the electromagnet causes the magnet to grip the armature surface of the brake drum more firmly. This results in increasing the pressure against the shoes and brake drums until the desired stop is accomplished.

Using your Brakes Properly

Your trailer brakes are designed to work in synchronization with your tow vehicle brakes. Never use your tow vehicle or trailer brakes alone to stop the combined load.

In order for your tow vehicle to provide the correct amperage flow to the trailer brake magnets for comfortable and safe braking it is imperative that you make the proper brake system adjustments. Changing trailer load and driving conditions as well as uneven alternator and battery output can mean unstable current flow to the brake magnets. It is therefore crucial that you maintain and adjust your brakes as set forth in this manual, use a properly modulated brake controller, and perform the synchronization procedure noted below.

In addition to the synchronization adjustment detailed below, electric brake controllers provide a modulation function that varies the current to the electric brakes with the pressure on the brake pedal or amount of deceleration of the tow vehicle. It is important that your brake controller provide approximately 2 volts to the braking system when the pedal is first depressed and gradually increases the voltage to 12 volts as brake pressure is increased. If the controller “jumps” immediately to a high voltage output, even during a gradual stop, then the electric brakes will always be fully energized and will result in harsh brakes and potential wheel lockup.

Proper synchronization of the tow vehicle to trailer braking can only be accomplished by road testing. Brake lockup, grabbiness, or harshness is quite often due to the lack of synchronization between the tow vehicle and the trailer being towed, too high of a threshold voltage (over 2 volts), or under adjusted brakes.

Before any synchronization adjustments are made, your trailer brakes should be burnished-in by applying the brakes 20 to 30 times with approximately a 20 mph decrease in speed, for example slowing from 40 to 20 mph each time. Allow ample time for the brakes to cool between application. This allows the brake shoes and magnets to slightly “wear-in” to the drum surfaces.

TD-24-T (5+20)

Synchronization

To insure safe braking performance and synchronization, *read the brake controller manufacturer's instructions completely before attempting any synchronization procedure.*

CAUTION ROAD SAFETY!

Before making road tests, make sure that the area is clear of vehicular and pedestrian traffic. The purpose of these tests is to adjust the brakes for safe operation, and therefore you should expect that initial braking action may be weak or irregular.

Make several hard stops from 20 mph on a dry paved road free of sand and gravel. If the trailer brakes lock and slide, decrease the gain setting on the controller. If they do not slide, slightly increase the gain setting. Adjust the controller just to the point of impending brake lockup and wheel skid.

Note: Minimum vehicle stopping distances are achieved when wheels approach lockup, however actual brake lockup should be avoided as it results in poor vehicle stability and control. Depending on load, brake type, wheels and tires, not all trailer brakes are capable of wheel lockup.

If the controller is applying the trailer brakes before the tow vehicle brakes, then the controller level adjustment should be adjusted so that the trailer brakes come on in synchronization with the tow vehicle brakes. For proper braking performance, it is recommended that the controller be adjusted to allow the trailer brakes to come on just slightly ahead of the tow vehicle brakes. When proper synchronization is achieved there will be no sensation of the trailer “jerking” or “pushing” the tow vehicle during braking.

CAUTION CONTROLLER PARAMETERS!

Do not adjust the brake controller outside the parameters outlined by the controller manufacturer's instructions.

Controllers

Start by making sure trailer brakes are properly adjusted. Some controllers have a gain control to vary the amount of current to the brakes, and a level control which sets the controller's inertia sensor to sense deceleration. The level adjustment also can be used to vary when the trailer braking is felt. The gain or output control adjustment usually controls the maximum amount of amperage available to the brakes. This can be adjusted for varying trailer loads.

Magnets

Your electric brakes are equipped with high quality electromagnets that are designed to provide the proper input force and friction characteristics. Your magnets should be inspected and replaced if worn unevenly or abnormally. As indicated below a straight-edge should be used to check wear.

Even if wear is normal as indicated by your straightedge, the magnets should be replaced if any part of the magnet coil has become visible through the friction material facing of the magnet. It is also recommended that the drum armature surface be refaced when replacing magnets. Magnets should also be replaced in pairs (both sides of the axle). Use only genuine Dexter replacement parts when replacing your magnets.

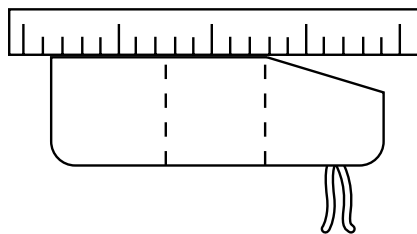

Abnormal Wear
(Replace Magnet)

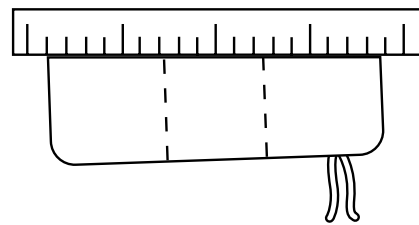

Normal Wear

TD-24-T (5+20)

Brake Cleaning and Inspection

Your trailer brakes must be inspected and serviced at yearly intervals or more often as use and performance requires. Magnets and shoes must be changed when they become worn or scored thereby preventing adequate vehicle braking.

CAUTION

RISK OF PERSONAL INJURY!

Whenever it becomes necessary to jack the trailer it is up to you to ensure that the trailer or axle is supported securely. Use blocks or jack stands on solid ground, especially if you are going to be working under the trailer.

Clean the backing plate, magnet arm, magnet, and brake shoes. Make certain that all the parts removed are replaced in the same brake and drum assembly. Inspect the magnet arms for any loose or worn parts. Check shoe return spring, hold down springs, and adjuster springs for stretch or deformation and replace if required. Check freedom of shoes. An actuated lever arm should snap back with shoes when released.

CAUTION

ASBESTOS DUST HAZARD!

Since some brake shoe friction materials contain asbestos, certain precautions need to be taken when servicing brakes:

- 1. Avoid creating or breathing dust.*
- 2. Avoid machining, filing or grinding the brake linings.*
- 3. Do not use compressed air or dry brushing for cleaning.
(Dust can be removed with a damp brush.)*

Brake Lubrication

Before reassembling, apply a light film of Lubriplate or similar grease, or anti-seize compound on the brake anchor pin, the actuating arm bushing and pin, and the areas on the backing plate that are in contact with the brake shoes and magnet lever arm. Apply a light film of oil on the actuating block mounted on the actuating arm.

Shoes and Linings

A simple visual inspection of your brake linings will tell if they are usable. Replacement is necessary if the lining is worn (to within $\frac{1}{16}$ " or less), contaminated with grease or oil, or abnormally scored or gouged. It is important to replace both shoes on each brake and both brakes of the same axle. This is necessary to retain the "balance" of your brakes. Consult the Parts section of this manual for part numbers and service kits available for proper replacement.

Electric Brake System Troubleshooting

Most electric brake system malfunctions that cannot be corrected by either brake adjustments or synchronization adjustments can generally be traced to electrical system failure. Mechanical causes are ordinarily obvious, i.e. bent or broken parts, worn out linings or magnets, seized lever arms or shoes, scored drums, loose parts, etc. A voltmeter and ammeter are essential tools for proper troubleshooting of electric brakes.

Measuring Voltage

System voltage is measured at the magnets by connecting the voltmeter between the two magnet lead wires at any brake. This may be accomplished by using a pin probe inserted through the insulation of the wires leading from the trailer frame to the brake assembly, or if necessary by cutting the wires. The engine of the tow vehicle should be running when checking the voltage so that a low battery will not affect the readings.

Voltage in the system should begin at zero volts and as the controller bar is slowly actuated should increase gradually to about 12 volts. This gradual increase of voltage is referred to as modulation. No modulation means that when the controller begins to apply voltage to the brakes it applies an immediate high voltage (acting more like an On-Off switch), which causes the brakes to apply instantaneous maximum power.

The threshold voltage of a controller is the voltage that is applied to the brakes when the controller first energizes. The lower the threshold the smoother the brakes will operate. Too high a threshold voltage (in excess of 2 volts as quite often found in heavy duty controllers) can cause grabby, harsh brakes.

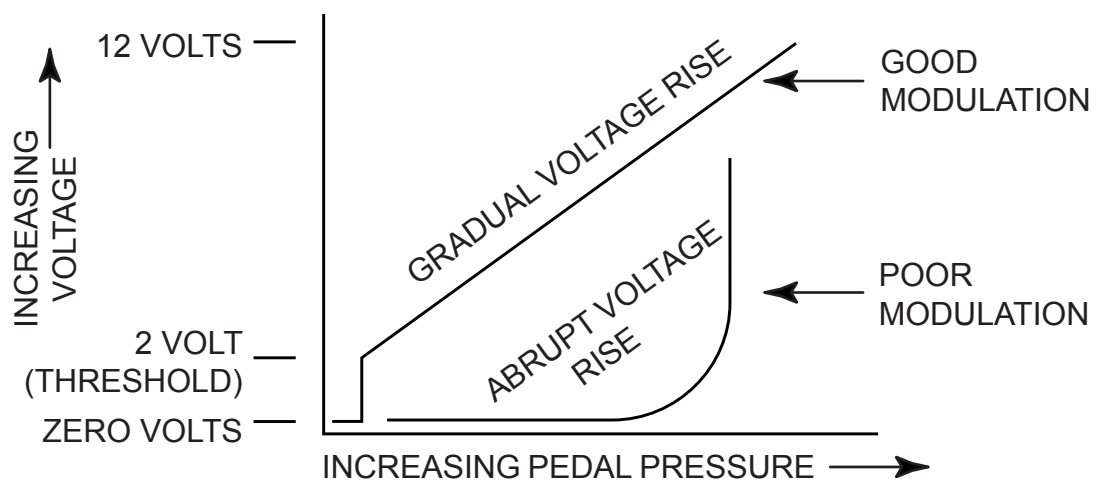

TD-24-T (5+20)

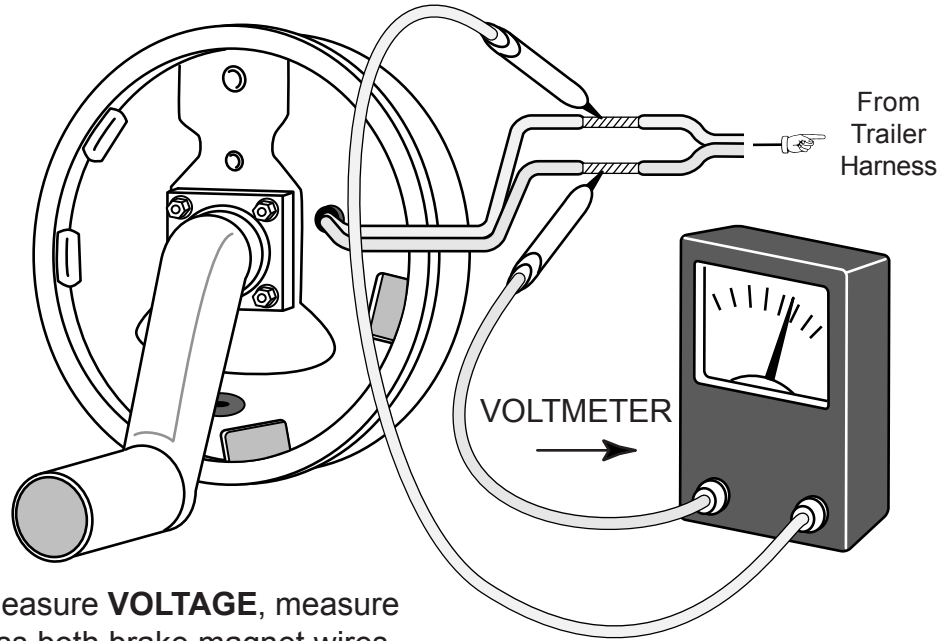

To measure **VOLTAGE**, measure across both brake magnet wires.

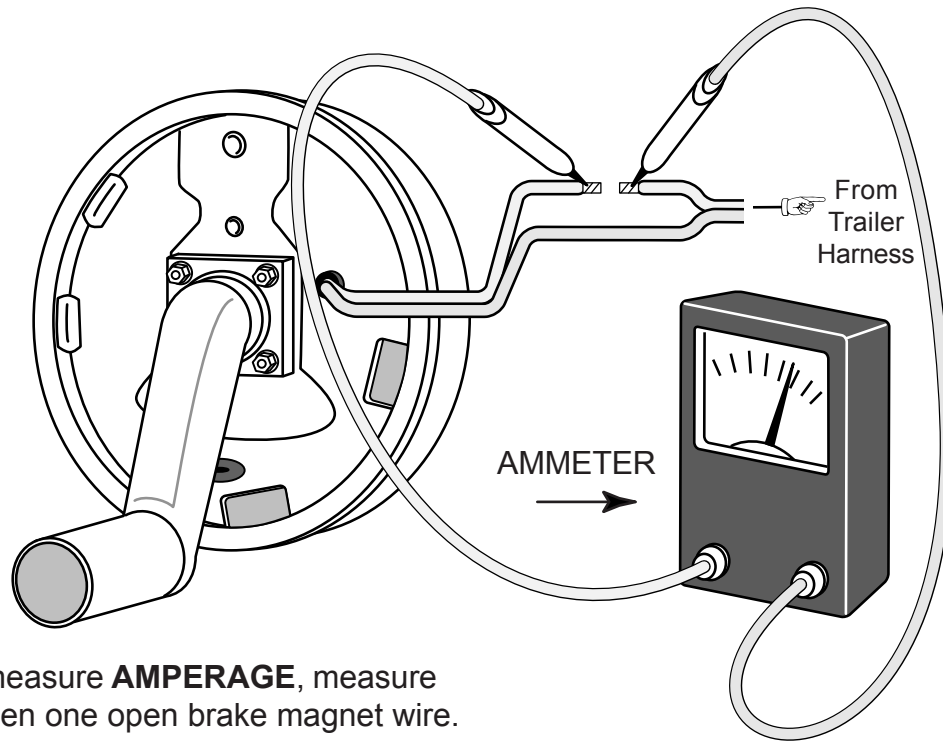

To measure **AMPERAGE**, measure between one open brake magnet wire.

Measuring Amperage

System amperage is the amperage being drawn by all the brakes on the trailer. The engine of the tow vehicle should be running when checking the amperage.

One place to measure system amperage is at the BLUE wire of the controller which is the output to the brakes. The BLUE wire must be disconnected and the ammeter put in series into the line. System amperage draw should be as noted in the paragraph below. Make sure your ammeter has sufficient capacity and be sure to connect it with the correct polarity to avoid damaging the meter.

If a resistor is used in the brake system it must be set at zero or bypassed completely to obtain the maximum amperage reading.

Individual brake amperage draw can be measured by inserting the ammeter in the line at the magnet you want to check. Disconnect one of the magnet lead wires and attach the ammeter between the two ends. Make sure that the wires are properly reconnected and sealed after testing is complete.

By far the most common electrical problem is low or no voltage and amperage at the brakes. Common causes of this condition are:

1. Poor electrical connections.
2. Open circuits.
3. Insufficient wire size.
4. Broken wires.
5. Blown fuses (fusing of brake circuits is not recommended).
6. Improperly functioning controllers or resistors.

Another common electrical problem is partially shorted circuits (indicated by abnormally high system amperage). These are occasionally the most difficult to find. Possible causes are:

1. Shorted magnet coils.
2. Defective controllers.
3. Bare wires contacting a grounded object.

TD-24-T (5+20)

Finding a system short is a matter of isolation. If the high amperage reading drops to zero by unplugging the trailer, the short is in the trailer. If the amperage reading remains high with all the brake magnets disconnected, the short is in the trailer wiring.

All electrical troubleshooting procedures should start at the controller. Most complaints regarding brake harshness or malfunction are traceable to improperly adjusted or non-functioning controllers. See your controller manufacturers data for proper adjustment and testing procedures. If the voltage and amperage is not satisfactory, proceed to the connector and then to the individual magnets to isolate the problem source. 12 volts output at the controller should equate to 10.5 volts minimum at each magnet. Nominal system amperage at 12 volts with the magnets at normal operating temperature, i.e. not cold, system resistor at zero and controller at maximum gain should be 3.0 amps for each magnet in the circuit.

Manual Brake Adjustment

Your brakes are designed with automatic adjusters. The following procedure can be used for manual adjustment after the brakes have been serviced.

CAUTION RISK OF PERSONAL INJURY!

Whenever it becomes necessary to jack the trailer it is up to you to ensure that the trailer or axle is supported securely. Use blocks or jack stands on solid ground, especially if you are going to be working under the trailer.

1. Jack up the trailer wheel on the brake being adjusted. Check that the wheel and drum rotate freely.
2. Remove the adjusting hole cover from the adjusting slot on the bottom of the brake backing plate.
3. With a screwdriver or standard adjusting tool rotate the star wheel of the brake adjuster assembly to expand the brake shoes. Adjust the shoes out until the pressure of the linings against the drum makes the wheel very difficult to turn.
4. Then rotate the star wheel in the opposite direction until the wheel turns freely with a slight lining drag. Replace the adjusting hole cover.
5. Repeat the above procedure on all brakes.

TD-24-T (5+20)

Electric Brake System Troubleshooting Chart

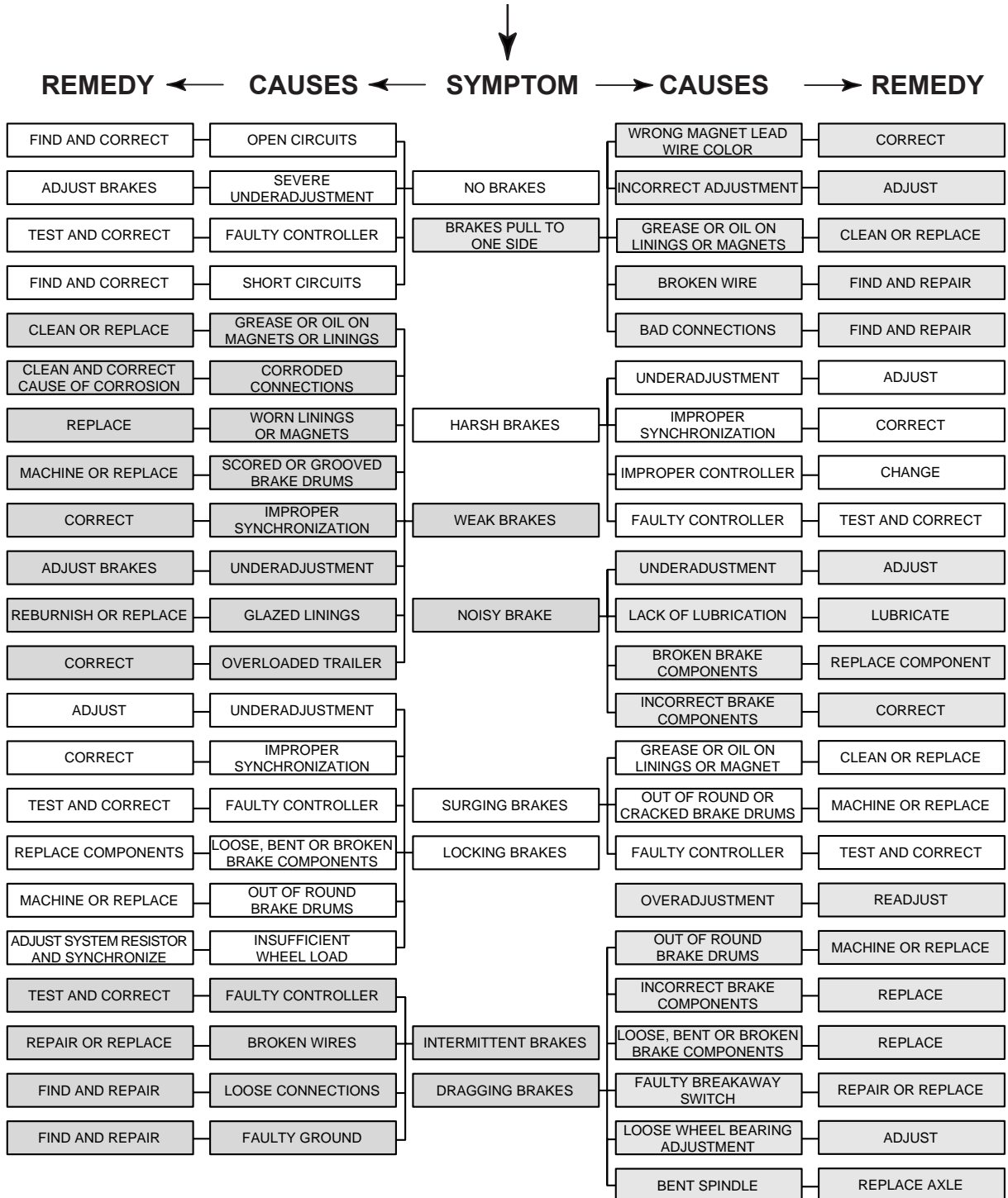

MAINTENANCE

TD-24-T (5+20)

2.9 Pre-Storage Maintenance

If your trailer is to be stored for an extended period of time or over the winter, it is important that the trailer be prepared properly.

1. Give the trailer a thorough wash down and let it dry completely.
2. Remove the breakaway battery (for electric brake systems) and store inside, out of the weather. Charge the battery at least every 90 days.
3. Jack up the trailer and place jack stands or blocks under the suspension tie plates so that the weight will be off the tires. The best way to jack the trailer for this is to place the jack under the trailer frame rail using a wood block to protect the finish. Raise the jack until the suspension assembly on that side is high enough to insert the blocks. Never jack or support the trailer using the axle tube or equalizers.
4. Lubricate exposed mechanical moving components such as the hitch and suspension parts. Store the trailer under cover for best protection, or under a tarp if cover is not available. Leaving the trailer out in the weather may cause accelerated aging.

2.10 Pre-Season Maintenance

Before removing the trailer from the jack stands:

1. Remove all wheels and hubs (brake drums). Note which spindles the drums were removed from so that they can be reinstalled in the same location.
2. Inspect the suspension for wear and corrosion and correct any discrepancies.
3. For leaf spring suspensions, check the tightness of all the hanger bolts, shackle bolts, and U-bolt nuts per recommended torque values.
4. Check all brake linings, brake drums and armature faces for excessive wear or scoring.
5. Check brake magnets with an ohmmeter. The magnets should check at approximately 3 ohms. If shorted or excessively worn, replace the magnets.
6. Lubricate all brake moving parts using a high temperature brake lubricant (Lubriplate or equivalent).



BRAKE LINING CONTAMINATION!

Do not get grease or oil on brake linings or magnet face.

7. Remove any rust from braking surface and armature surface with fine emery paper or crocus cloth. Protect the bearings from contamination while so doing.
8. Inspect oil seals for wear or nicks. Replace if necessary.
9. Reinstall the hubs and adjust bearings as outlined in this manual.
10. Refill hubs with correct quantity of oil.
10. Remount wheels and torque the wheel lug nuts. Be sure to remember to re-torque the lugs periodically.
11. Check cold tire inflation pressures (LT245/75R 16 "E"- 80 psi).

TD-24-T (5+20)

Section 3. Parts

3.1 Structural Components

Sub-frame

| Ref. | Quantity | Description | Part No. |
|------|----------|--------------------------------------|------------------------------------|
| 1. | 1 | Sub-frame Assembly | A-10139 |
| 2. | 2 | Safety Chain and Hook Assembly | ³ / ₈ " ASSY |
| 3. | 2 | Deck Lumber | 2" X 12" X 20' |

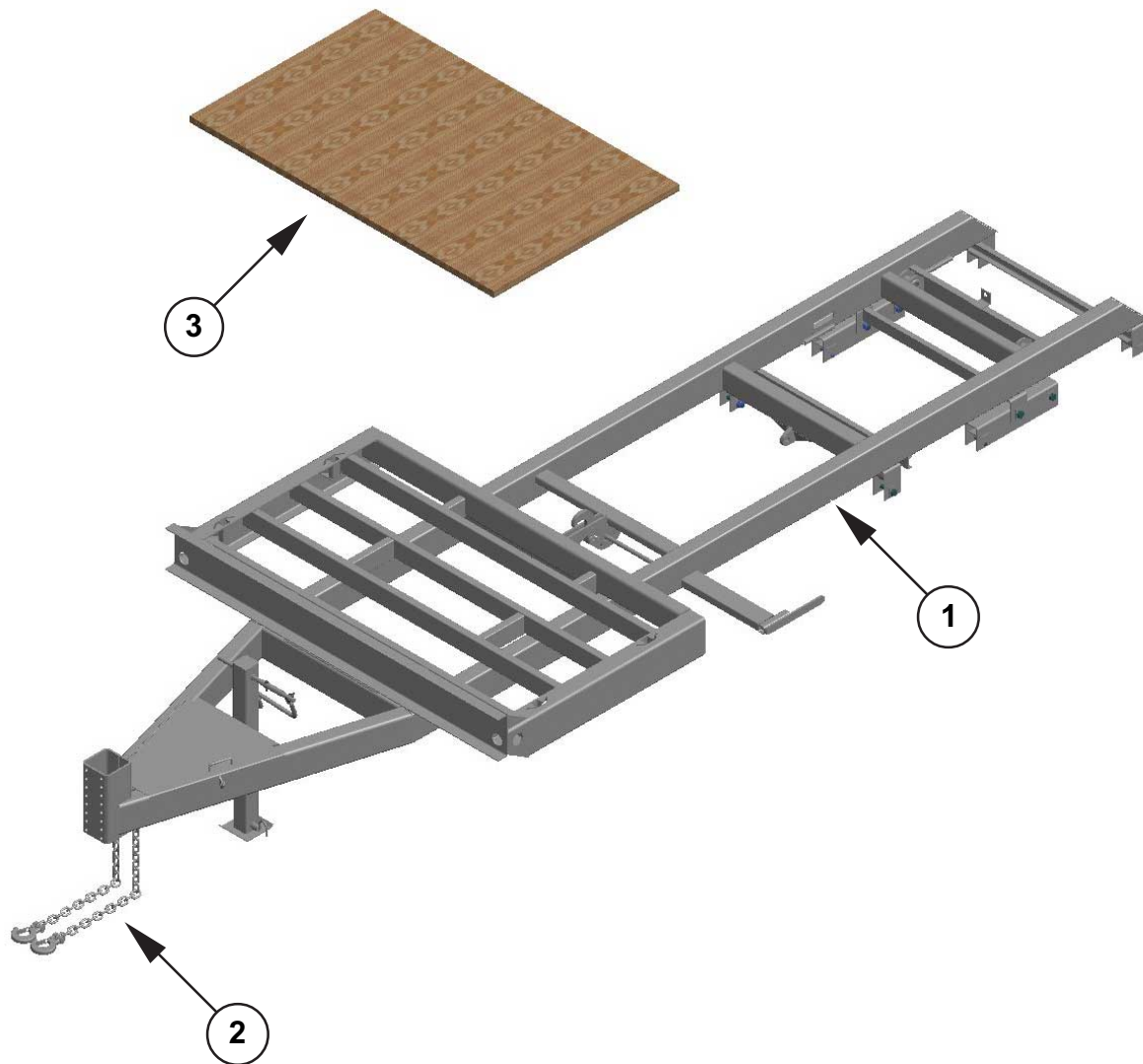

TD-24-T (5+20)

Deck Assemblies

| Ref. | Quantity | Description | Part No. |
|------|----------|------------------------|----------------|
| 1. | 1 | Deck Assembly | A-10019 |
| 2. | 2 | Step Assembly | SA-04069 |
| 3. | 2 | Deck Lumber | 2" X 8" x 20' |
| | 4 | Deck Lumber | 2" X 10" x 20' |
| | 2 | Deck Lumber | 2" X 10" X 24' |
| | 1 | Deck Lumber | 2" X 12" X 24' |
| 4. | 2 | TrailMax Mudflap | B30PCB |
| 5. | 2 | Mudflap Bracket | MFW 2375 |

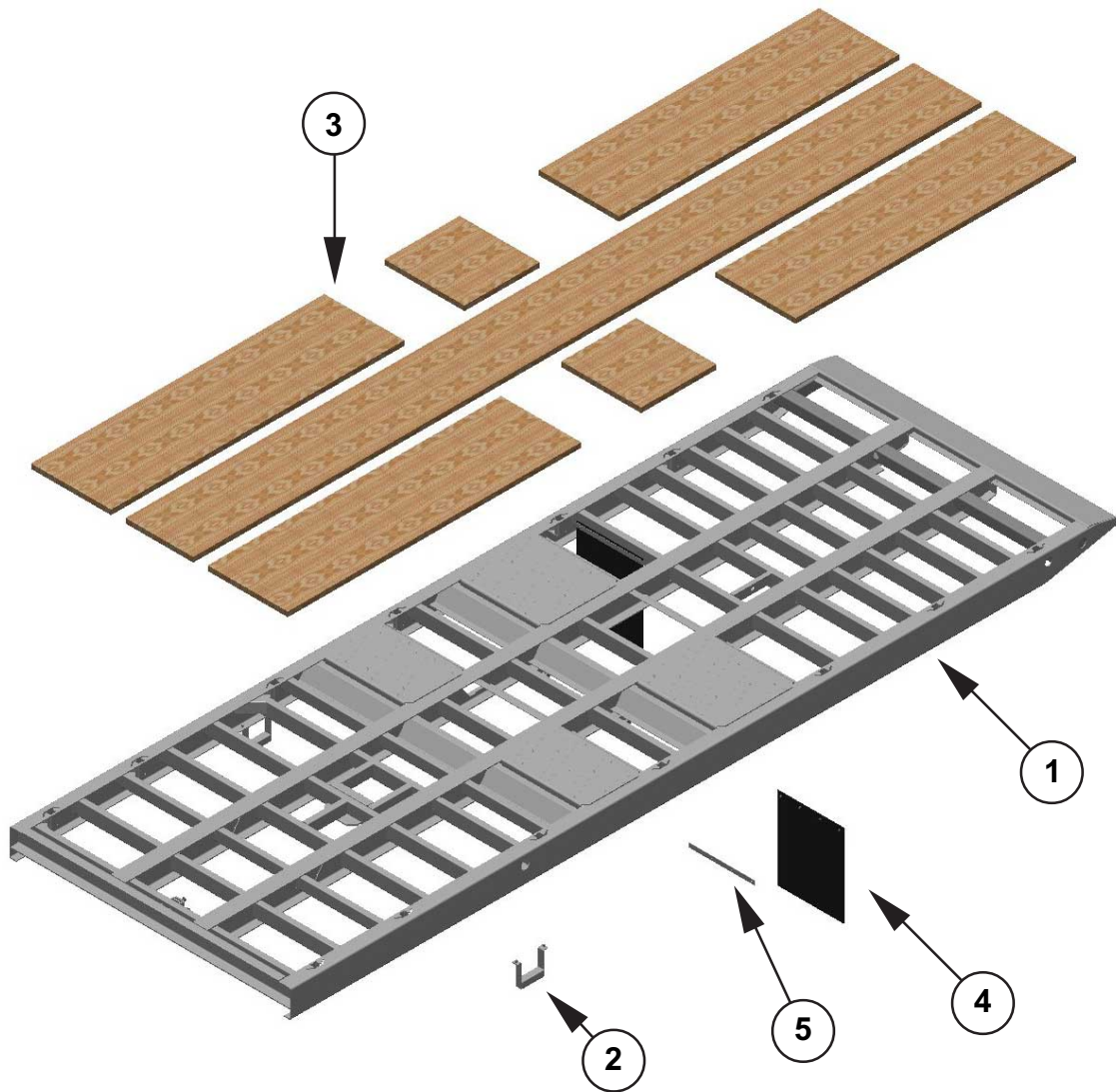

PARTS

TD-24-T (5+20)

3.2 Major Sub-Assemblies

Drawbar Eye

| Ref. | Quantity | Description..... | Part No. |
|------|----------|------------------------------------|--------------|
| 1. | 1 | Drawbar Eye..... | BDB-1250-15D |
| 2. | 4 | 3/4" x 2-1/2" Bolt Grade 8 NF..... | 18992 |
| 3. | 4 | 3/4" Lock Washer..... | 33632 |
| 4. | 4 | 3/4" Hex Nut Grade 8 NF..... | 36466 |

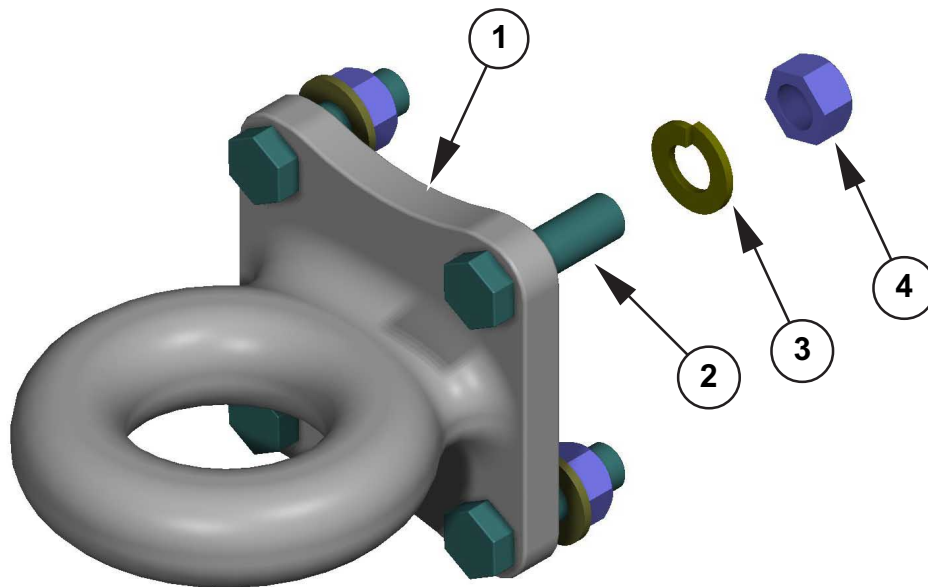

TD-24-T (5+20)

Binkley Jack

| Ref. | Quantity | Description | Part No. |
|------|----------|-----------------------------|-----------|
| 1. | 1 | Binkley Jack | 48000 |
| 2. | 1 | Universal Crank | LG0083-01 |
| 3. | 1 | Jack Handle Extension | SA-04291 |

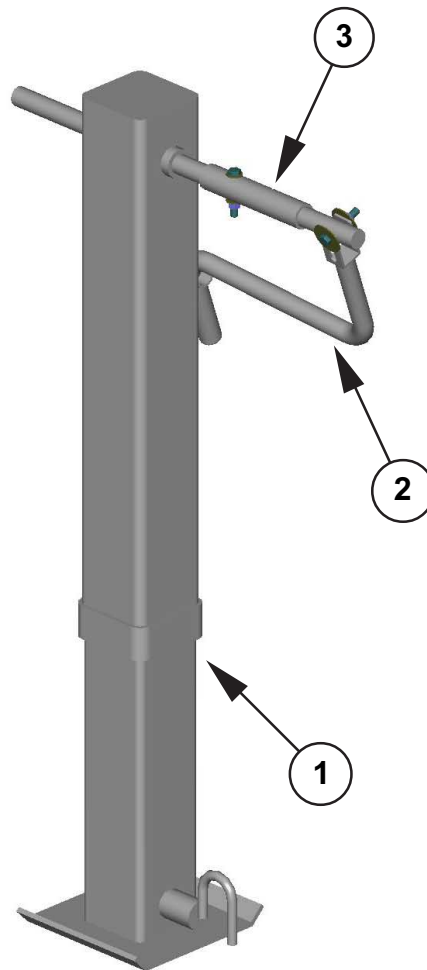

P
A
R
T
S

TD-24-T (5+20)

Cushion Cylinder

| Ref. | Quantity | Description | Part No. |
|------|----------|--------------------------------|----------|
| 1. | 1 | Cushion Cylinder, 4 x 16 | SA-03027 |

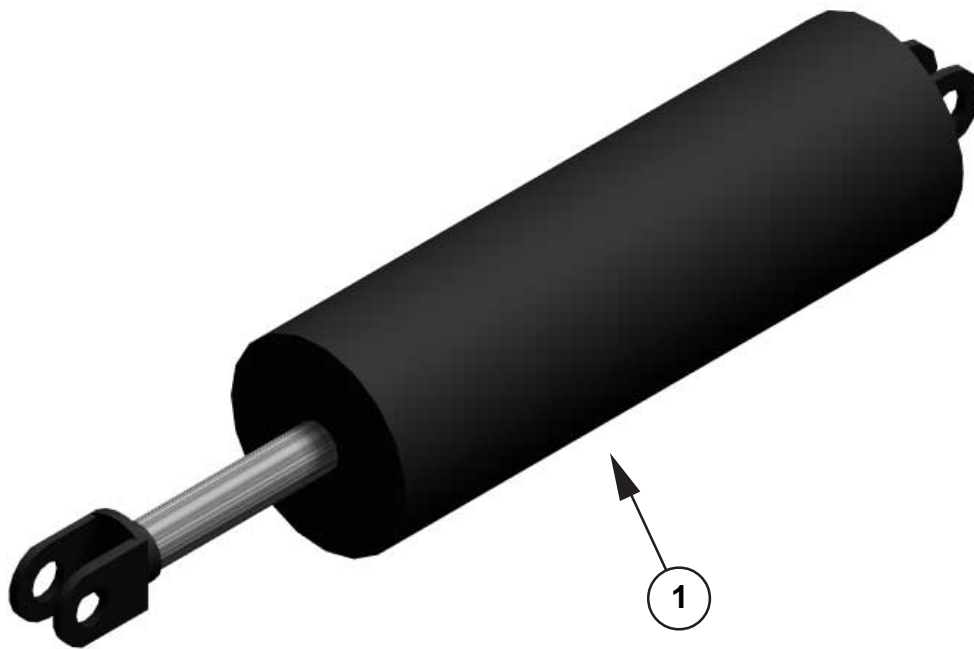

TD-24-T (5+20)

Deck Latch Assembly

| Ref. | Quantity | Description..... | Part No. |
|------|----------|-----------------------------|-------------|
| 1. | 1 | Latch Assembly | SA-03114 |
| 2. | 1 | Roll Pin, 3/8" x 2" | 64315 |
| 3. | 8 | Flanged Bushing | GFI-1618-08 |
| 4. | 6 | E-clip SE 982 D | 10385-00128 |
| 5. | 3 | Groove Pin | C-06050 |
| 6. | 1 | Safety Pin Assembly | 10385-00161 |

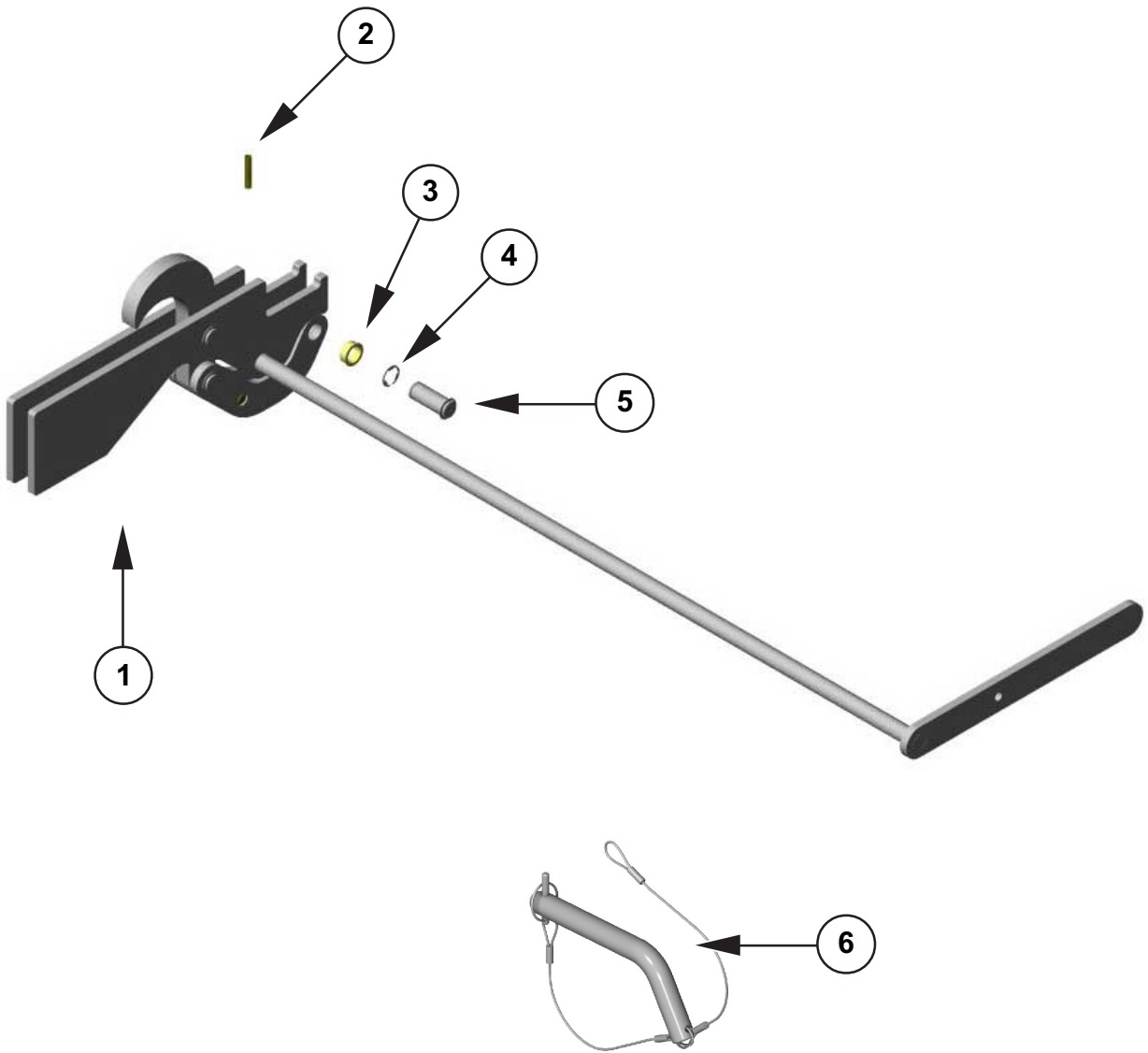

PARTS

TD-24-T (5+20)

Deck Hinge Assembly

| Ref. | Quantity | Description | Part No. |
|------|----------|---------------------------------|----------|
| 1. | 1 | Deck Hinge Assembly | SA-03160 |
| 2. | 2 | Hinge Bracket Assembly | SA-07099 |
| 3. | 2 | Hinge Pin | C-12665 |
| 4. | 2 | Lock Nut, 3/8" NF | 37304 |
| 5. | 2 | Bolt, 3/8" x 3- 1/2" Grade 8 NF | 18846 |
| | 2 | Grease Fitting | 60105 |

Note: Kit names are **bold type** while component names are regular type; kit components are indexed under the kit name. Kit component quantities are per kit; other parts and kit quantities are per trailer.

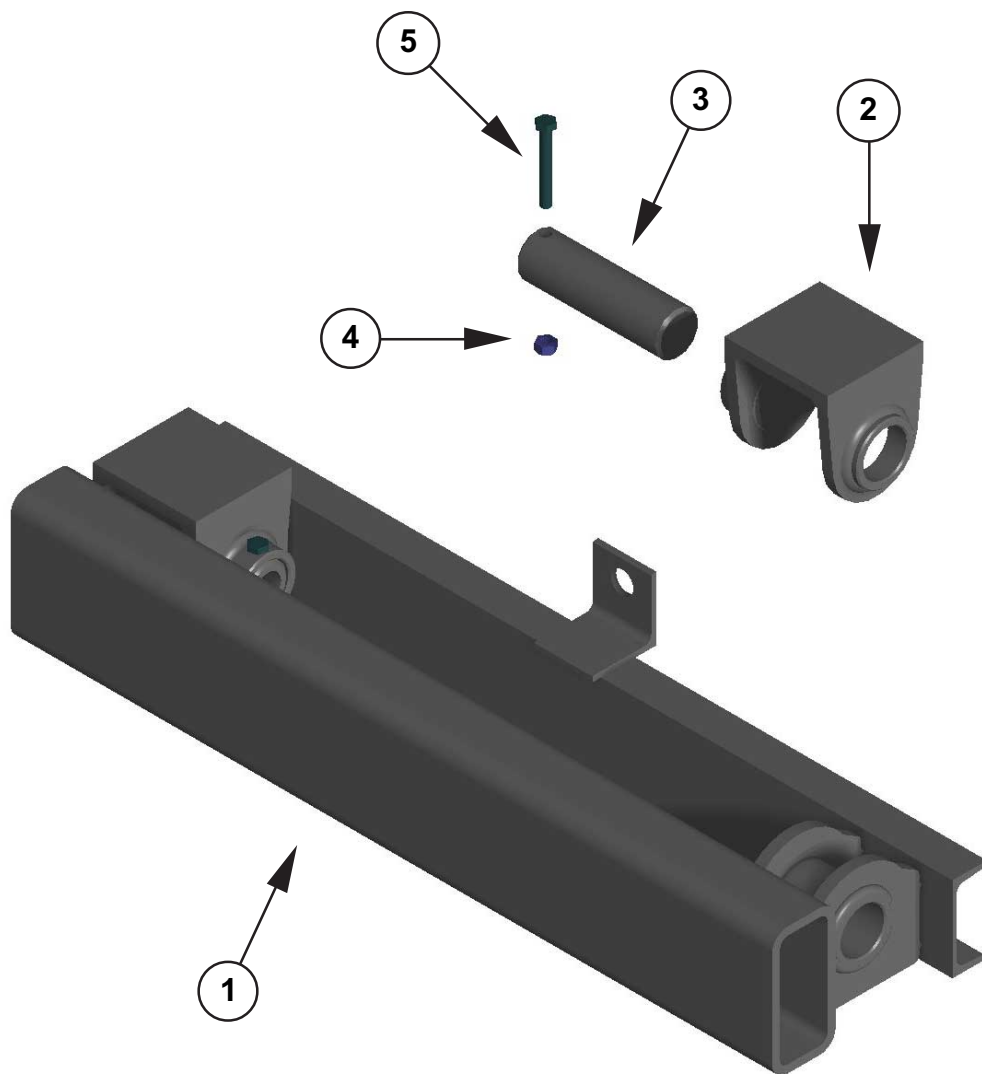

TD-24-T (5+20)

3.3 Rear Impact Guard (RIG) Assembly

| Ref. | Quantity | Description | Part No. |
|------|----------|----------------------------------------------------|----------|
| 1. | 1 | Rear Impact Guard Assembly | SA-09038 |
| 2. | 1 | RIG Light Bar | SA-10198 |
| 3. | 1 | RIG Pushrod | SA-12516 |
| 4. | 1 | Torsion Block Assembly | C-06128 |
| 5. | 1 | Adjustable Radius Rod | 16398-04 |
| 6. | 1 | Torsion Block Pivot Pin | C-12229 |
| 7. | 2 | Linkage Pin, Short | C-12239 |
| 8. | 1 | Linkage Pin, Long | C-12249 |
| 9. | 1 | Pushrod Bolt ($\frac{9}{16}$ " x 3" shackle bolt) | B-3 |
| 10. | 1 | Pushrod Nut (for shackle bolt) | N-3 |
| 11. | 2 | Crush Block Assembly | SA-12368 |
| 12. | 1 | Hinge Pin Assembly | SA-12454 |

Note: Kit names are **bold type** while component names are regular type; kit components are indexed under the kit name. Kit component quantities are per kit; other parts and kit quantities are per trailer.

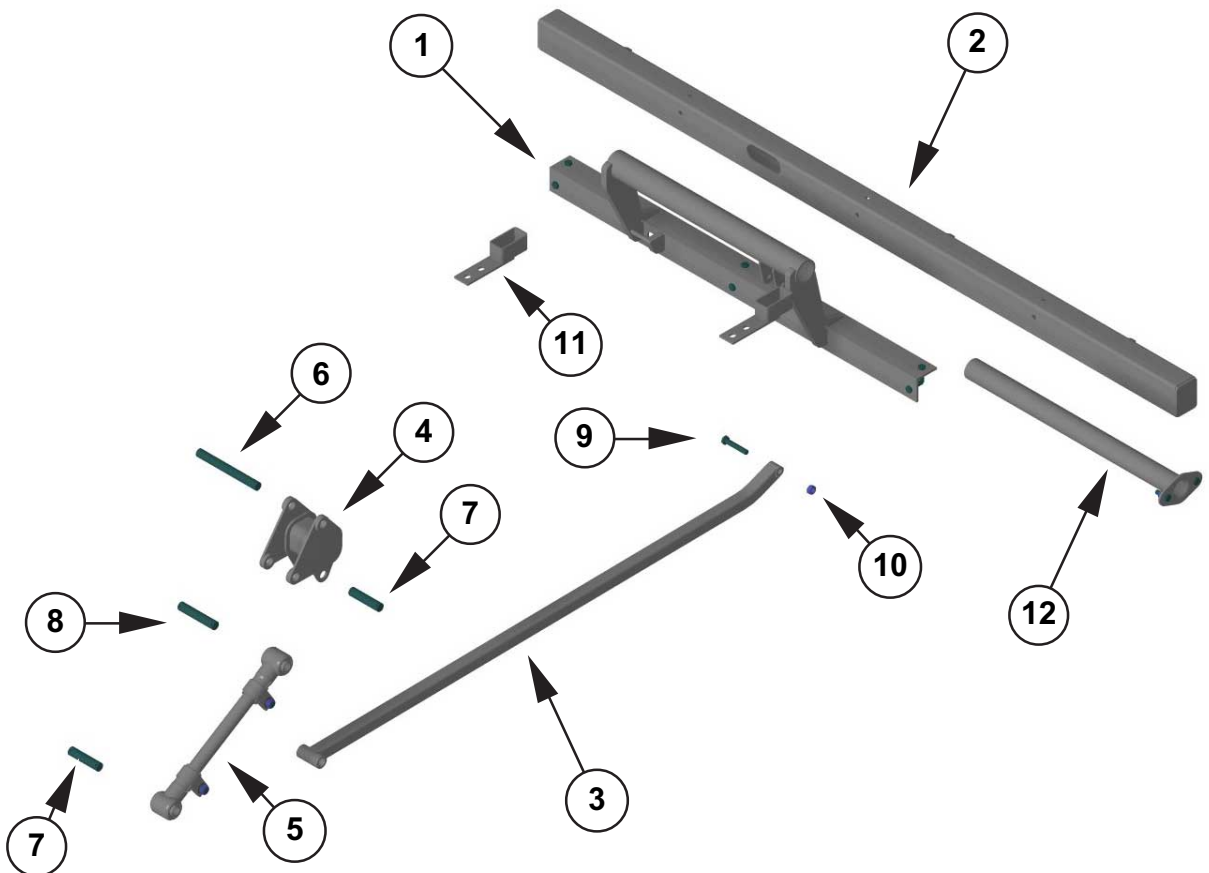

PARTS

TD-24-T (5+20)

3.4 Running Gear, 12K

Suspension

| Ref. | Quantity | Description | Part No. |
|------|----------|-----------------------------------------------|-------------------|
| 1. | 1 | Axle Assembly, 12K Air Brake, Front | 12KA-SPR. ABS PKG |
| | 1 | Axle Assembly, 12K Air Brake, Rear | 12K SER-PKG |
| | 2 | Axle Assembly, 12K Electric Brake | 12KE-SPR PKG |
| | 1 | Single Axle Hanger and Parts Kit | HAP-103-00 |
| 2. | 2 | Front Hanger | 028-067-04 |
| 3. | 2 | Rear Hanger | 030-066-01 |
| 4. | 2 | Spring Eye Bolt | 007-169-00 |
| 5. | 2 | Keeper Bolt | 007-095-00 |
| 6. | 2 | Lock Nut | 006-112-00 |
| 7. | 2 | Lock Nut | 006-046-00 |
| | 2 | Decal | 059-160-00 |
| | 1 | Multi-Axle Conversion Kit | HAP-203-03 |
| 4. | 2 | Spring Eye Bolt | 007-169-00 |
| 5. | 2 | Keeper Bolt | 007-095-00 |
| 6. | 2 | Lock Nut | 006-112-00 |
| 7. | 2 | Lock Nut | 006-046-00 |
| 8. | 2 | Center Hanger | 029-037-04 |
| 9. | 1 | L.H. Equalizer | 013-109-03 |
| | 1 | R.H. Equalizer | 013-109-04 |
| 10. | 2 | Equalizer Bolt | 007-170-00 |
| 11. | 2 | Lock Nut | 006-072-00 |
| 12. | 8 | U-bolt | 011-070-00 |
| 13. | 4 | Leaf Spring Adjuster | 003-173-01 |
| 14. | 4 | Leaf Spring Assembly | 072-044-01 |
| 15. | 4 | Bottom Plate | 012-046-00 |
| 16. | 16 | Lock Nut | 006-113-00 |

Note: Kit names are **bold type** while component names are regular type; kit components are indexed under the kit name. Kit component quantities are per kit; other parts and kit quantities are per trailer.

TD-24-T (5+20)

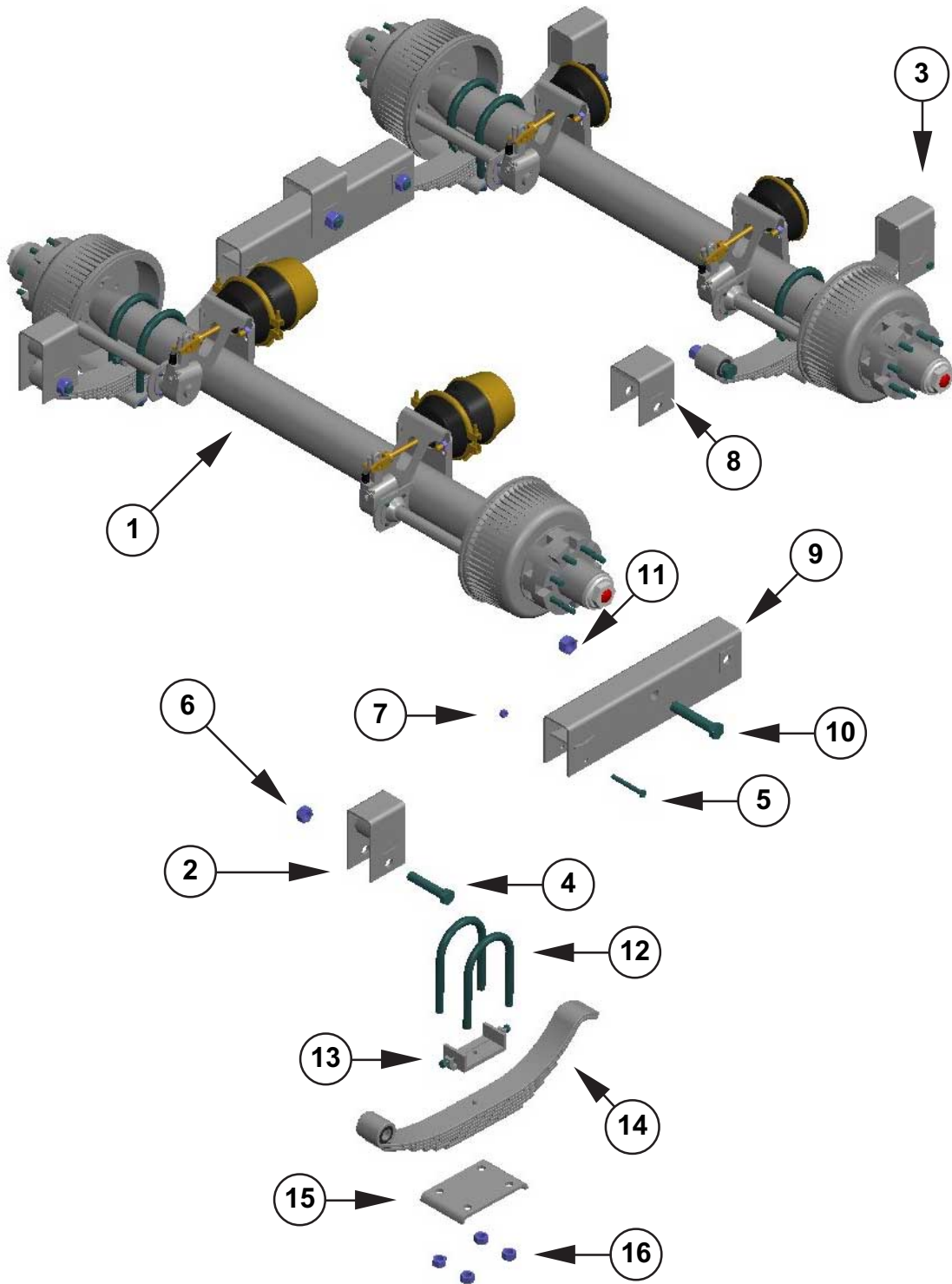

PARTS

TD-24-T (5+20)

Axle End Components, 12K

| Ref. | Quantity | Description | Part No. |
|------|----------|-----------------------------------|----------|
| 1. | 1 | Unitized Oil Seal | 10-56 |
| 2. | 1 | Inner Bearing Cone | 3984 |
| 3. | 1 | Inner Bearing Cup | 3920 |
| 4. | 8 | Drum Mounting Screw | 7-103 |
| 5. | 1 | Brake Drum | 9-28-1 |
| 6. | 1 | Hub with Cups and Studs, RH | 8-214-8 |
| 7. | 1 | Locating Pin | 56-8 |
| 8. | 8 | Wheel Mounting Stud, RH | 7-115 |
| 9. | 1 | Outer Bearing Cup | 28622 |
| 10. | 1 | Outer Bearing Cone | 28682 |
| 11. | 1 | Tang Washer | 5-59 |
| 12. | 2 | Spindle Nut | 6-84 |
| 13. | 1 | Spindle Washer | 5-60 |
| 14. | 1 | Oil Cap O-ring | 10-50 |
| 15. | 1 | Oil Cap | 21-37 |
| 16. | 1 | Oil Cap Plug | 46-32 |

Note: Quantities shown are per axle end.

TD-24-T (5+20)

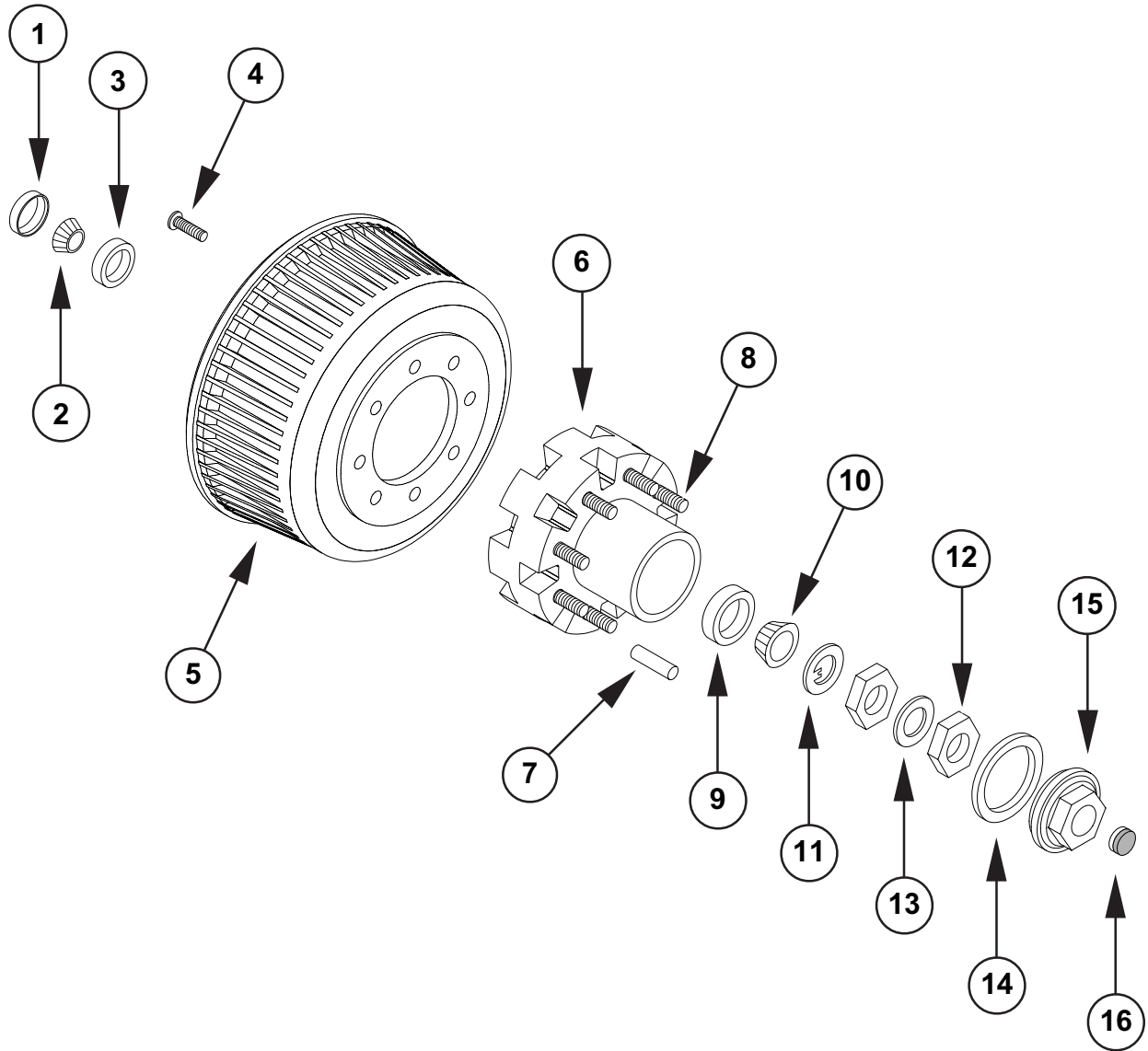

PARTS

TD-24-T (5+20)

Air Brake Components, 12K

| Ref. | Quantity | Description | Part No. |
|------|----------|------------------------------------------------|---------------|
| 1. | 1 | Camshaft, LH..... | 34-14-1 |
| | 1 | Camshaft, RH | 34-15-1 |
| | | Camshaft Repair Kit (for 1 brake) | 71-101 |
| 2. | 1 | “D” Washer, Camshaft | 5-74 |
| 3. | 2 | Grease Seal | 10-52 |
| 4. | 1 | Camshaft Bushing | 14-56 |
| 5. | 1 | Grease Fitting | 61-3 |
| 6. | 2 | Camshaft Washer | 5-75 |
| 7. | 2 | Camshaft Retainer | 69-20 |
| 8. | 1 | Camshaft Support Bushing | 14-58 |
| | | Shoe Repair Kit (for 1 brake) | 71-98 |
| 9. | 2 | Roller | 14-57 |
| | 2 | Roller Pin | 56-10 |
| | 2 | Roller Pin Retainer | 69-18 |
| 10. | 2 | Anchor Pin | 56-11 |
| | 4 | Anchor Pin Washer | 5-73 |
| | 4 | Anchor Pin Retainer | 69-19 |
| 11. | 1 | Anchor Pin Clamping Screw | 7-137 |
| 12. | 2 | Retractor Spring Retainer Pin | 56-12 |
| 13. | 1 | Retractor Spring | 46-92 |
| 14. | 1 | Shoe and Roller Assembly, RH | 40-165-3 |
| | 1 | Shoe and Roller Assembly, LH | 40-165-2 |
| | 2 | Shoe and Block Assembly | 40-165-1 |
| | 1 | Brake Block Kit | 71-152 |
| 15. | 4 | Brake Block, Anchor Side | 41-53-01 |
| 16. | 4 | Brake Block, Cam Side | 41-53-02 |
| | 24 | Rivet | 22-18 |
| 17. | 1 | Brake Spider (weld on) | 26-80-2 |

Note: Quantities shown are per brake.

TD-24-T (5+20)

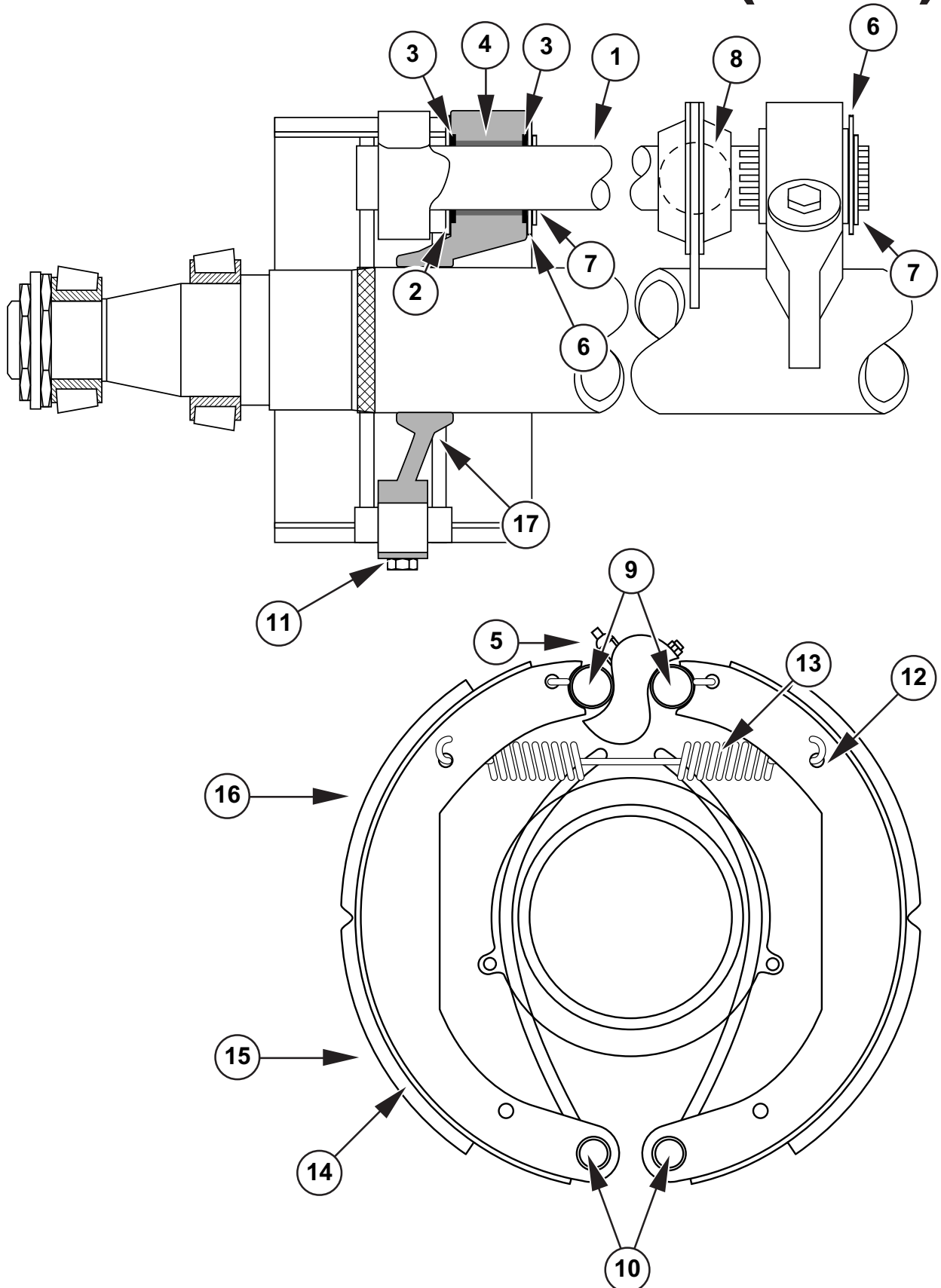

PARTS

TD-24-T (5+20)

Electric Brake Components, 12K

| Ref. | Quantity | Description | Part No. |
|------|----------|-----------------------------------------|----------|
| 1. | 1 | Shoe and Lining Kit, LH | 71-53 |
| | 1 | LH Primary | 40-102-1 |
| | 1 | LH Secondary | 40-103-2 |
| | 2 | Shoe Hold Down Washer | 5-107 |
| | 2 | Castle Nut | 6-77 |
| | 2 | Cotter Pin | 19-12 |
| 1. | 1 | Shoe and Lining Kit, RH | 71-54 |
| | 1 | RH Primary | 40-103-1 |
| | 1 | RH Secondary | 40-102-2 |
| | 2 | Shoe Hold Down Washer | 5-107 |
| | 2 | Castle Nut | 6-77 |
| | 2 | Cotter Pin | 19-12 |
| 2. | 1 | Backing Plate Assembly | 36-72-6 |
| 3. | 1 | Shoe Return Spring, Rear (Black) | 46-71 |
| 4. | 1 | Shoe Return Spring, Front (Green) | 46-83 |
| 5. | 1 | Actuating Arm Assembly, LH | 47-71-1 |
| | 1 | Actuating Arm Assembly, RH | 47-72-1 |
| 6. | 3 | Cable Tie | 27-15 |
| 7. | 1 | Arm/Shoe Retainer, LH | 71-16 |
| | 1 | Arm/Shoe Retainer, RH | 71-16-1 |
| 8. | 1 | Flange Nut | 6-62 |
| | 1 | Magnet Kit | 71-108 |
| 9. | 1 | Magnet Retainer Clip | 46-55 |
| 10. | 1 | Magnet Assembly | 42-107 |
| 11. | 1 | Magnet Mounting Spring | 46-79 |
| 12. | 1 | Cable Guide | 71-18 |
| 13. | 1 | Adjuster Cable | 71-20 |
| 14. | 1 | Adjuster Lever, LH | 71-19-1 |
| | 1 | Adjuster Lever, RH | 71-19-2 |
| 15. | 1 | Adjuster Lever Spring, LH | 46-73 |
| | 1 | Adjuster Lever Spring, RH | 46-74 |
| 16. | 1 | Pivot Pin | 71-17 |
| 17. | 1 | Adjuster Spring | 46-72 |
| 18. | 1 | Adjuster Assembly, LH | 48-9 |
| | 1 | Adjuster Assembly, RH | 48-10 |
| 19. | 7 | Brake Mounting Screw | 7-116 |
| 20. | 7 | Brake Mounting Nut | 6-92 |
| 21. | 1 | Dust Cover, Top | 36-76-1 |
| 22. | 1 | Dust Cover, Bottom | 36-76-2 |
| 23. | 1 | Sleeve | 27-14 |

Note: Quantities shown are per brake.

Parts

TRAILMAX®

TD-24-T (5+20)

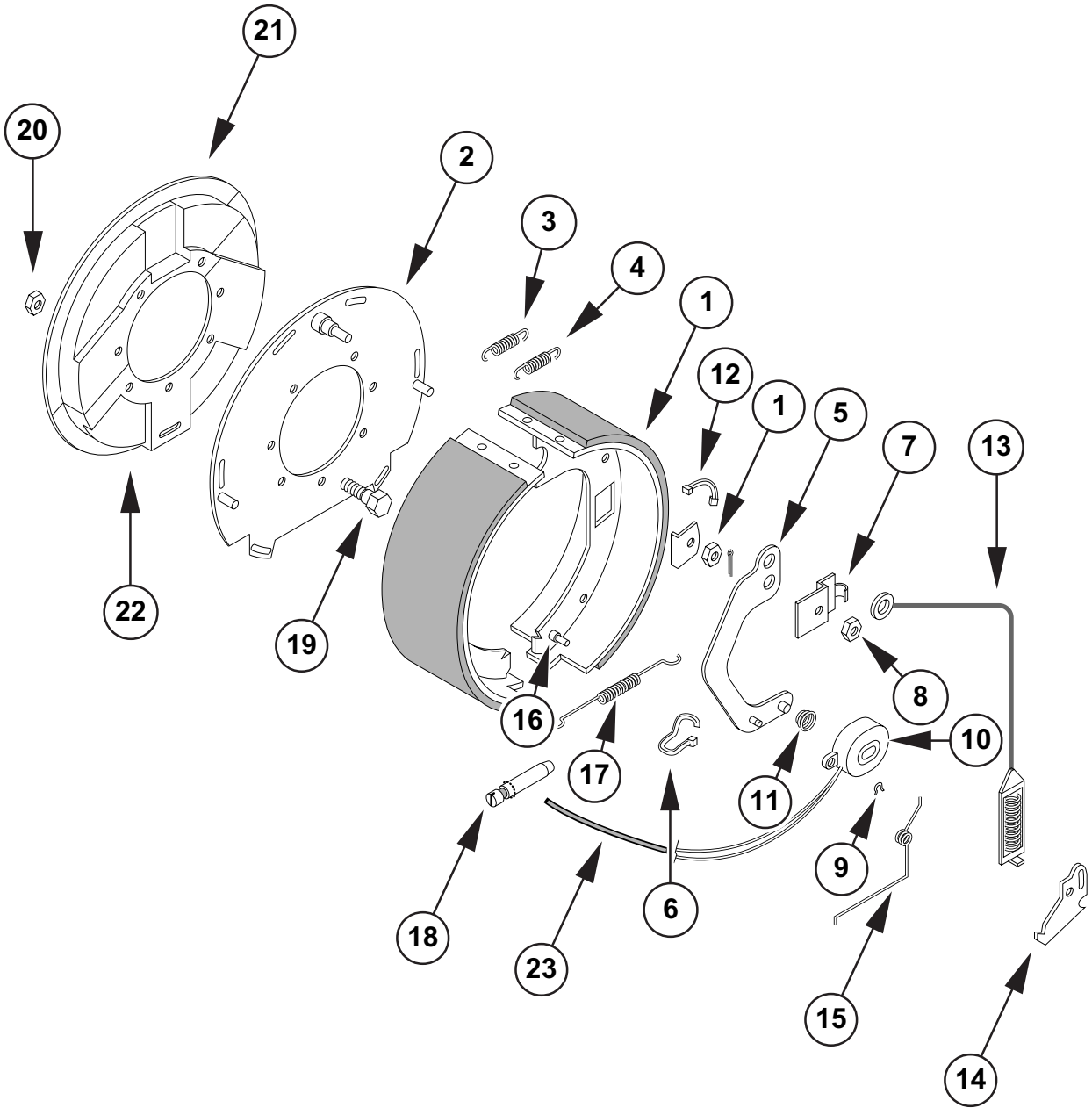

PARTS

TD-24-T (5+20)

3.5 Wheels and Tires

| Ref. | Quantity | Description | Part No. |
|------|----------|--------------------------|--------------|
| 1. | 2 | Tire | 245/75R 16 |
| 2. | 2 | Wheel, 17.5 x 6.75 | 17-279-14 SP |
| 3. | 2 | Valve Stem | 501 |
| 4. | 1 | Clamp Ring | 33-52-1 |
| 5. | 8 | Wheel Nut | 6-109 |

Note: Tires are not available through Gem State Manufacturing; contact your local equipment tire retailer for replacement parts.

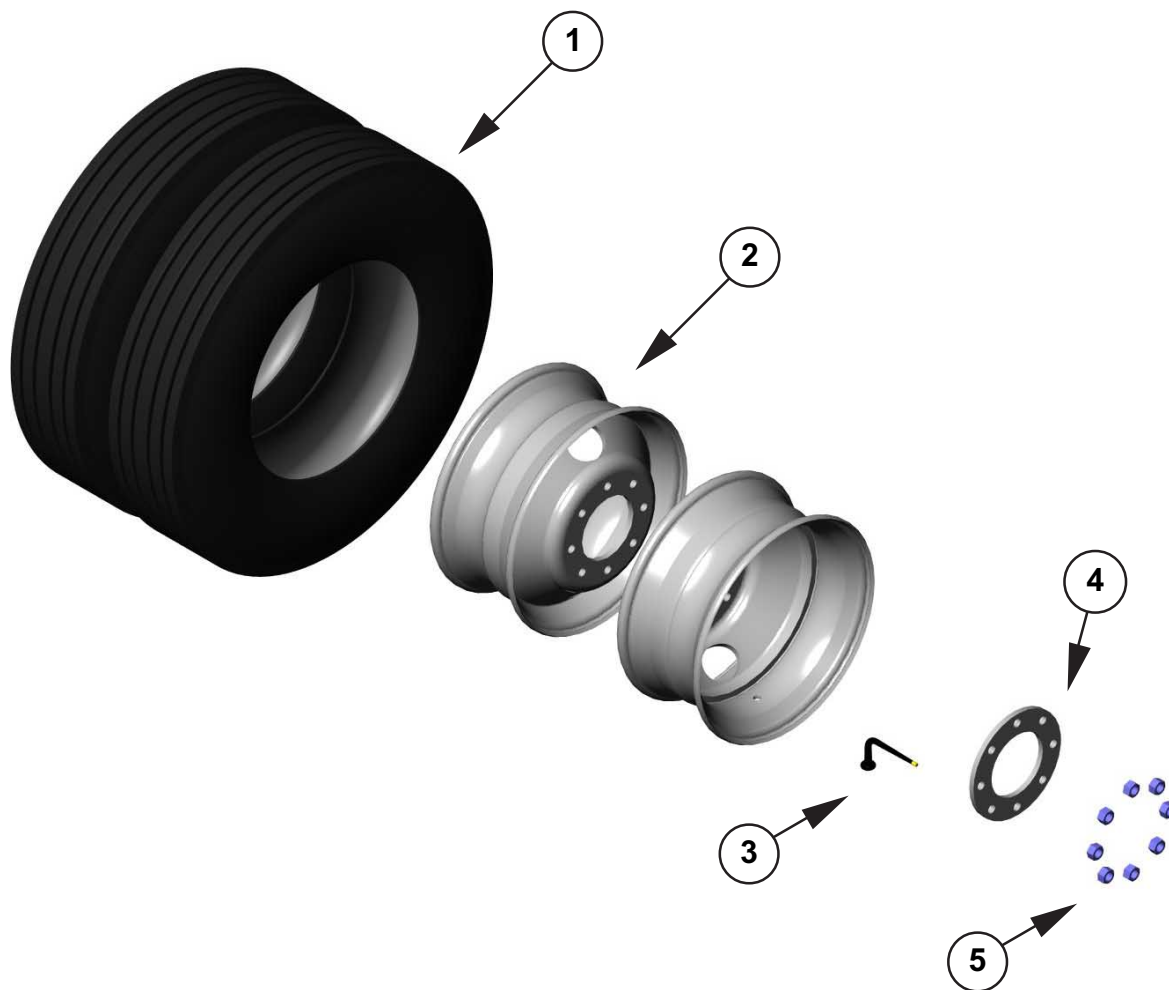

THIS PAGE LEFT BLANK INTENTIONALLY

**P
A
R
T
S**

TD-24-T (5+20)

3.6 Electrical

Harnesses and Lights

| Ref. | Quantity | Description | Part No. |
|------|----------|-----------------------------------------|----------|
| | 1 | E-11 Electrical Kit | K01433B |
| 1. | 1 | Harness, Main Feed | 93738 |
| 2. | 1 | Harness, Rear Impact Guard | 93737 |
| 3. | 1 | Harness, Stationary Deck Marker | 50393 |
| 4. | 1 | Harness, Marker | 50358 |
| 5. | 4 | Amber clearance lamp, sealed | 10205Y |
| 6. | 9 | Mounting grommet | 10704 |
| 7. | 5 | Red clearance lamp, sealed | 10205R |
| 8. | 4 | Oval stop/turn/tail light, sealed | 60202R |
| 9. | 4 | Oval mounting grommet | 60700 |
| 10. | 1 | License plate lamp | 26331 |
| 11. | 2 | Boot Kit, 2 connector | 77850 |
| | 1 | Boot Kit, 6 & 7 connector | 77852 |
| | 3 | Boot Kit, Filler | 77853 |
| | 1 | Boot Kit, 4 & 5 connector | 77851 |
| 12. | 1 | Junction Box, 8 way | 77808 |
| | 1 | Harness Clip | 97011 |

Note: Kit names are **bold type** while component names are regular type; kit components are indexed under the kit name. Kit component quantities are per kit; other parts and kit quantities are per trailer.

TD-24-T (5+20)

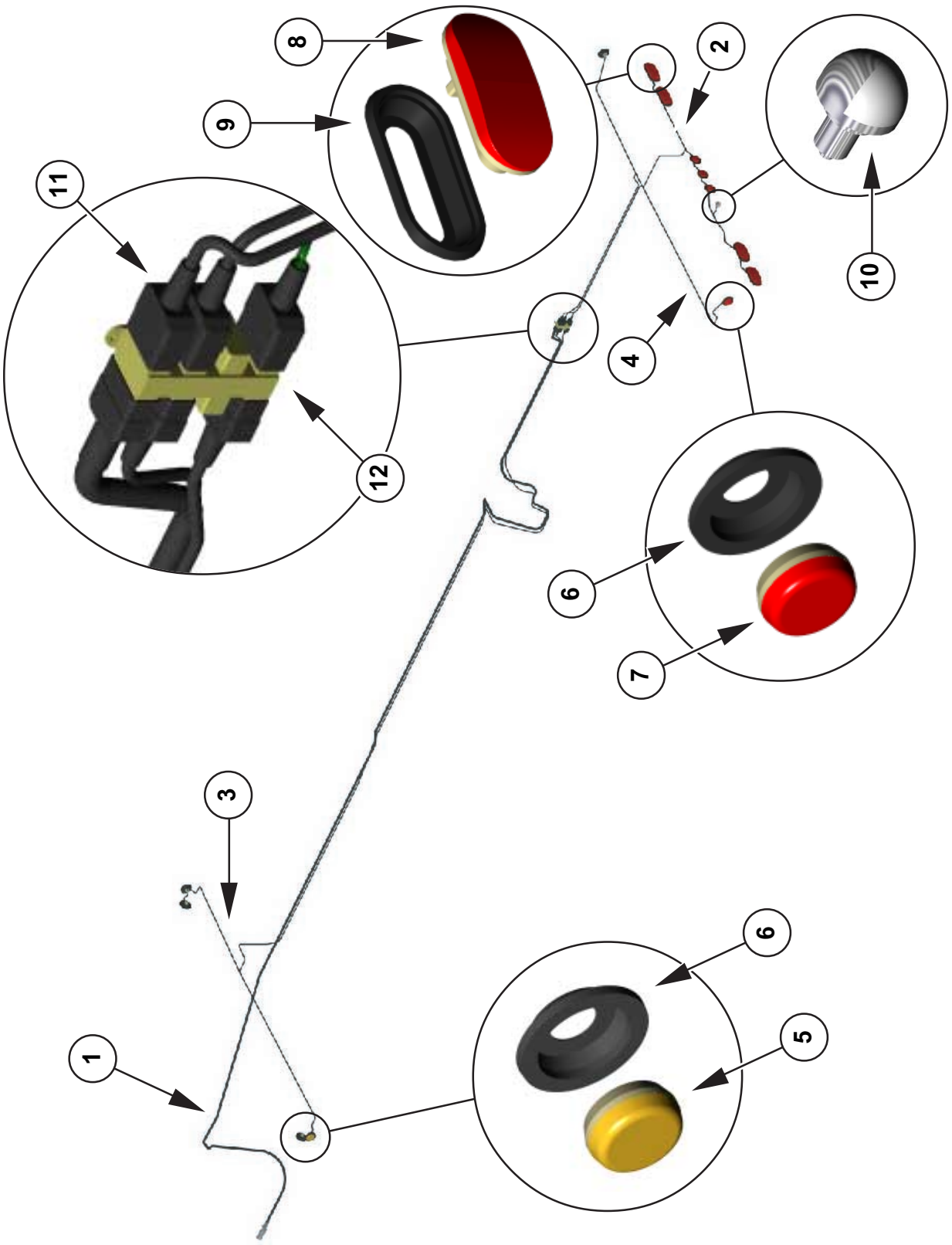

PARTS

TD-24-T (5+20)

Electrical Plug

| Ref. | Quantity | Description | Part No. |
|------|----------|---------------------------------|-----------|
| 1. | 1 | Seven Way Plug and Spring | PL 15-730 |

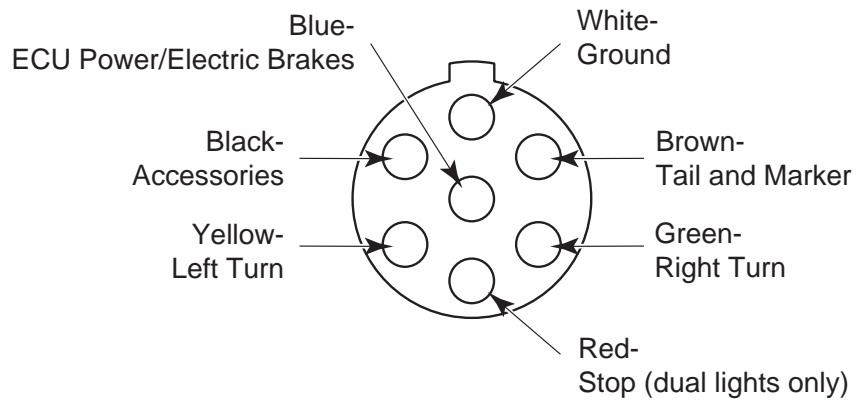
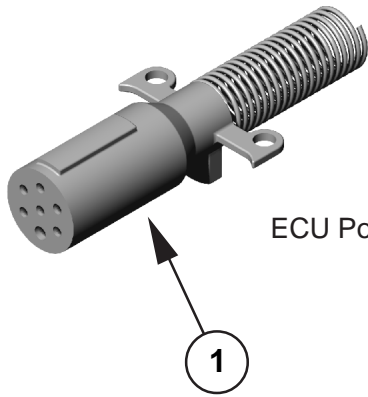

ABS Electrical

| Ref. | Quantity | Description | Part No. |
|------|----------|---------------------------------|--------------|
| | 1 | E-9 Electrical Kit | K01185C |
| 1. | 1 | Harness, ABS | 52200 0240 |
| 2. | 1 | Amber ABS lamp, sealed | 30257Y |
| 3. | 1 | Mounting Grommet | 30700 |
| 4. | 1 | Boot Kit, 2 conductor | 77850 |
| | 1 | Boot Kit, 4 & 5 conductor | 77851 |
| 5. | 2 | *Sensor Extension Cable | OW4497130080 |
| 6. | 1 | *ABS Power Cable | OW4493280300 |

Note: Kit names are **bold type** while component names are regular type; kit components are indexed under the kit name. Kit component quantities are per kit; other parts and kit quantities are per trailer. *These items are included in the A-1 ABS Air Kit.

TD-24-T (5+20)

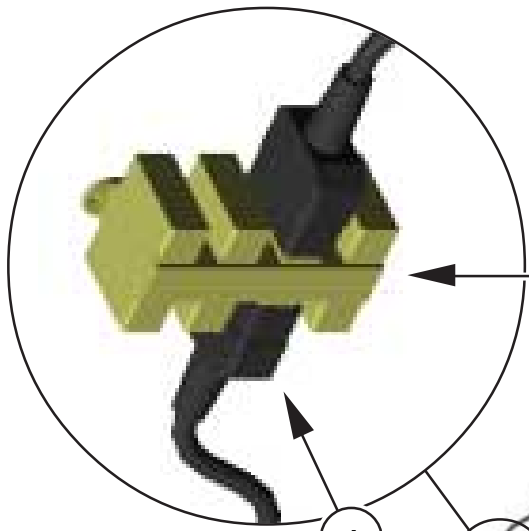

Junction Box shown
for reference only

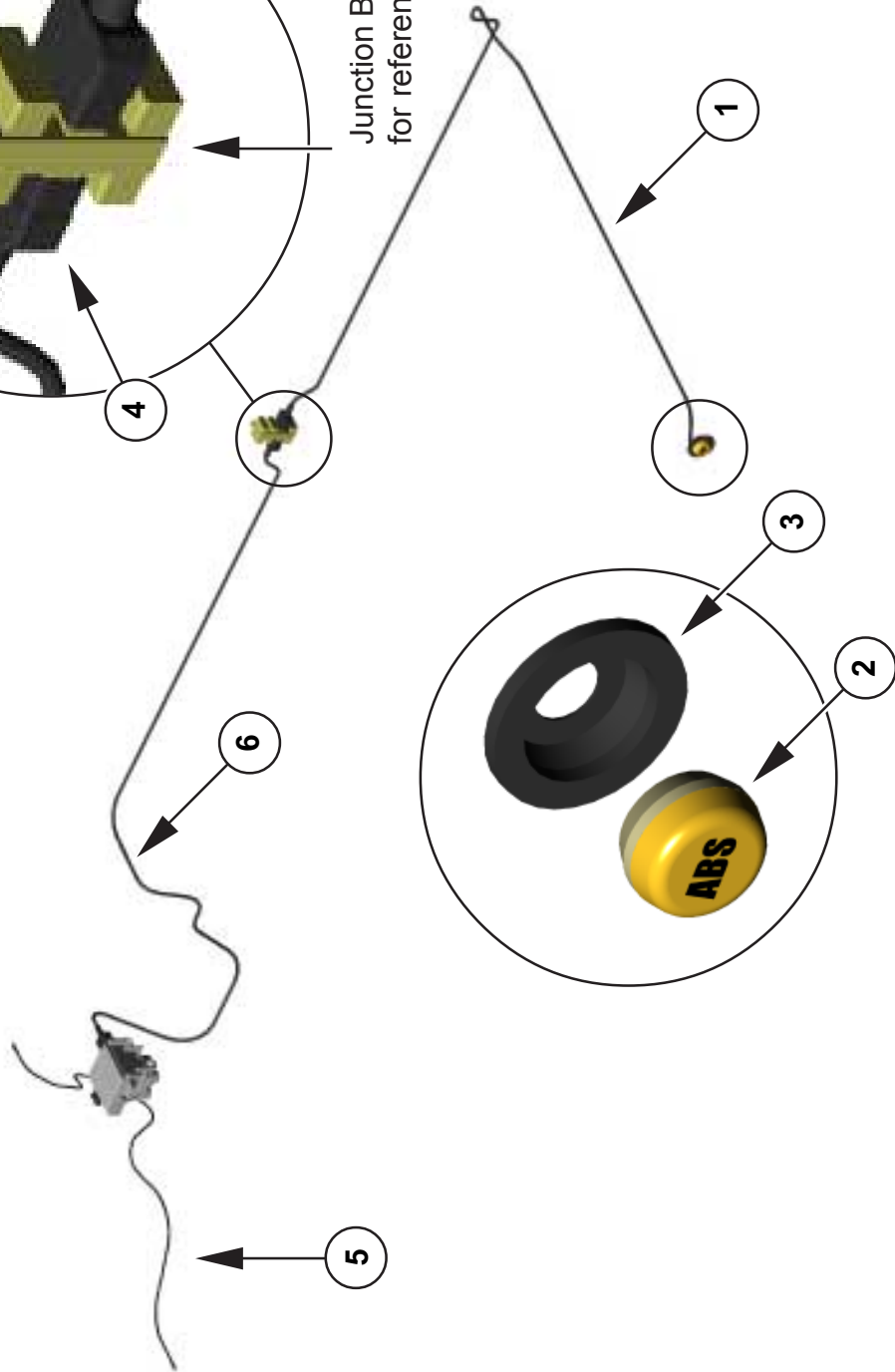

PARTS

TD-24-T (5+20)

| Ref. | Quantity | Description | Part No. |
|------|----------|---------------------------------|----------|
| | 1 | E-6 Electrical Kit | 51306 |
| 1. | 1 | Harness, Electric Brake | 512332 |
| 2. | 1 | 3/8" Connector Kit | 77850 |

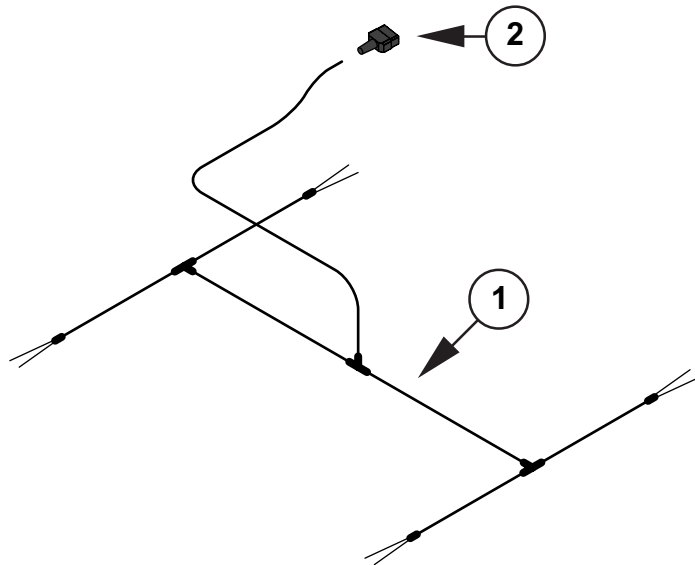

TD-24-T (5+20)

Electric Breakaway System

| Ref. | Quantity | Description | Part No. |
|------|----------|------------------------------|----------|
| 1. | 1 | Electric Breakaway Kit | 110898 |

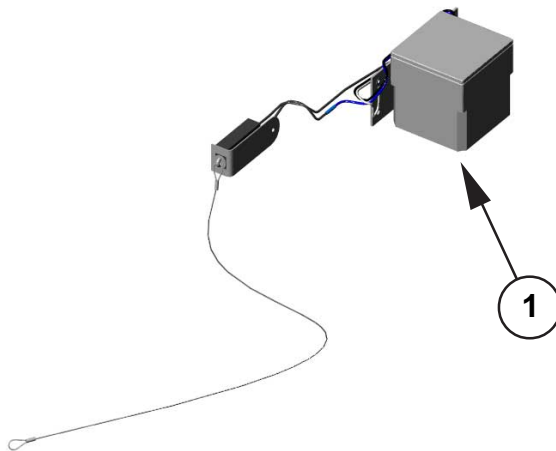

PARTS

TD-24-T (5+20)

3.7 Air Brake System

Because of the complexity of the air brake system, the components are displayed graphically over the next several pages.

| Ref. | Quantity | Description | Part No. |
|------|----------|----------------------------------------|----------------|
| | 1 | Tandem Axle Air Kit/ABS | A-1 ABS |
| 1. | 1 | Service Gladhand | PL12-006 |
| 2. | 1 | Emergency Gladhand | PL12-008 |
| 3. | 2 | Hose Assembly, 1/2" x 1/2" x 60" | TA32003-060 |
| 4. | 2 | Male Elbow, 3/8" x 3/8" | PBVS269NTA-6-6 |
| 5. | 2 | Male Elbow, 1/2" x 3/8" | PBVS269NTA-8-6 |
| 6. | 3 | Terminal Bolt | MI11304 |
| 7. | 2 | 90° Union Elbow | PB2200P-8-8 |
| 8. | 264" | 1/2" Nylon Tubing, Red | NTPFT8BREDIN0E |
| 9. | 264" | 3/8" Nylon Tubing, Black | NTPFT6BIN0E |
| 10. | 1 | Air Tank, 9508/1488 | AT9534 |
| 11. | 2 | Hose Assembly, 3/8" x 3/8" x 32" | TA32002-032 |
| 12. | 1 | Hose Assembly, 3/8" x 3/8" x 28" | TA32002-028 |
| 13. | 2 | Hose Assembly, 3/8" x 3/8" x 56" | TA32002-056 |
| 14. | 2 | Hose Assembly, 3/8" x 3/8" x 62" | TA32002-0062 |
| 15. | 6 | Street Elbow, 90° | PB2202P-6-6 |
| 16. | 1 | Drain Cock | PBDC604-4 |
| 17. | 2 | Allen Head Pipe Plug | SI3/4 |
| | 2 | Hex Head Plug | PB218P-4 |
| | 4 | Hex Head Plug | PB218P-6 |
| 18. | 1 | Electronic Control Unit (ECU) | OW4005001020 |
| 19. | 1 | Pipe Nipple | OS60060E |
| 20. | 1 | Male Branch Tee 3/8" x 1/4" | PBVS272NTA-6-4 |
| | 1 | Male Branch Tee 3/8" x 3/8" | PBVS272NTA-6-6 |
| 21. | 1 | Spring Brake Control Valve | OS1105000E |

Note: Kit names are **bold type** while component names are regular type; kit components are indexed under the kit name. Kit component quantities are per kit; other parts and kit quantities are per trailer.

TD-24-T (5+20)

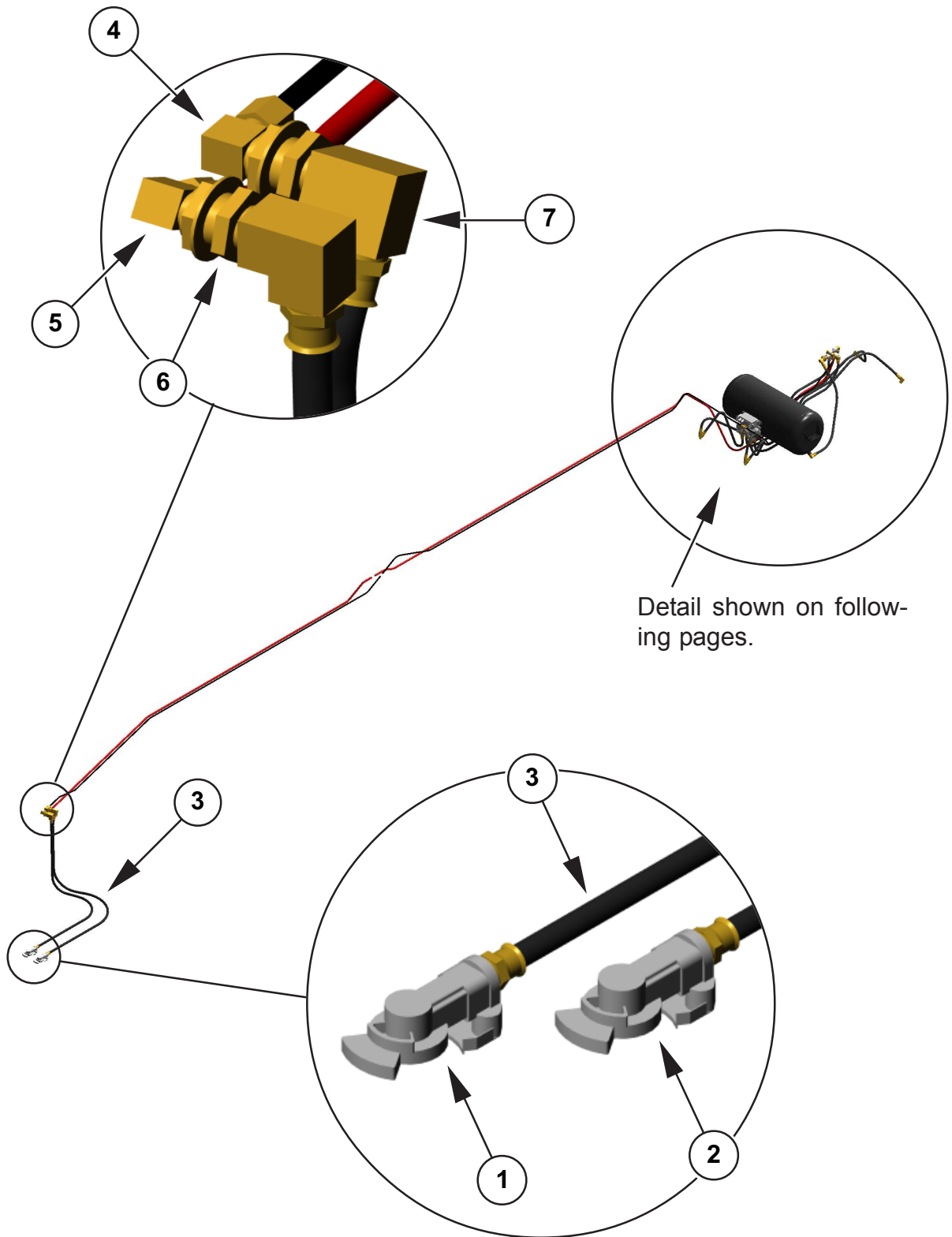

PARTS

TD-24-T (5+20)

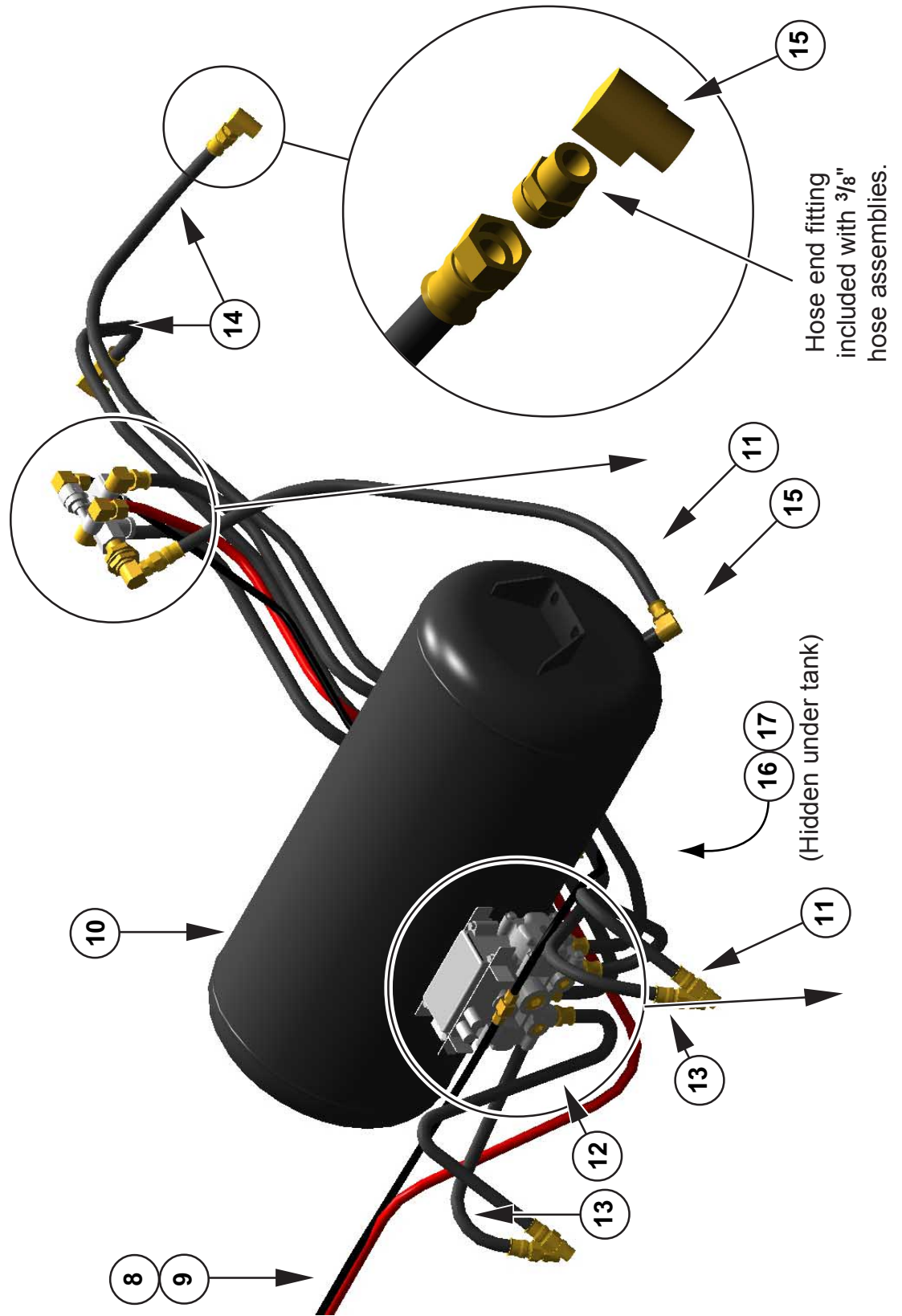

TD-24-T (5+20)

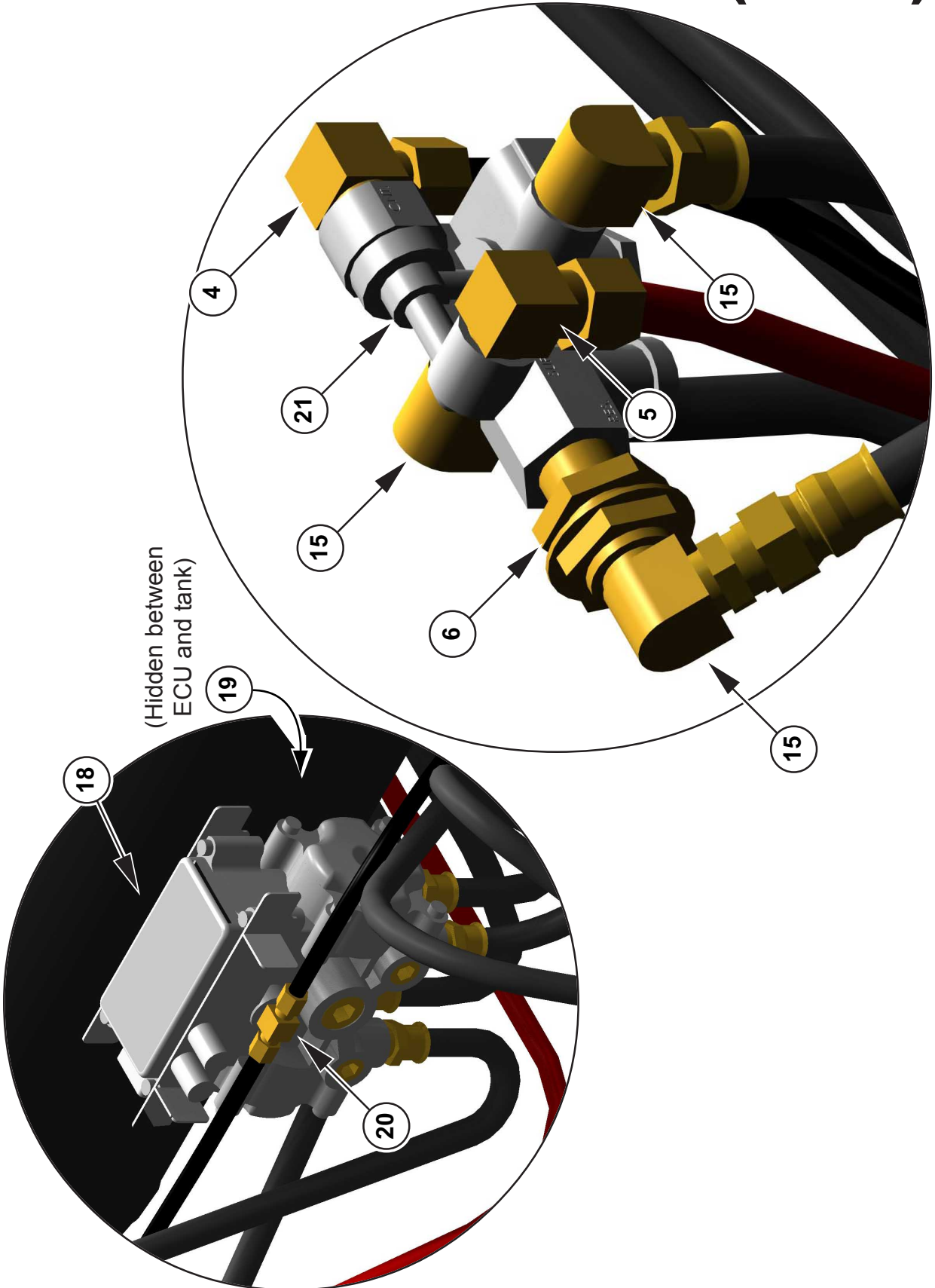

PARTS

TD-24-T (5+20)

Section 4. Warranty Claim Procedure

At Gem State Manufacturing, we insist on a high level of quality materials and workmanship that go into every TrailMax trailer. Ultimately this will minimize the need for frequent service and warranty claims. However, in the event of a claim, we want to be as responsive as possible.

In the event that you have a problem with your trailer that may be warranty related, your cooperation is appreciated when the following steps are followed in an effort to process the claim expeditiously.

1. Have the trailer V.I.N. (Vehicle Identification 17 digit Number) and model No. available.
2. Refer to the Operators Manual when identifying defective parts. If the claim is structural related, photos may be required and are helpful in determining how to correct the problem. (Digital photo's can be sent via e-mail to customerservice@trailmax.com in *.jpg or *.jpeg format.)
3. Contact a TrailMax representative in your immediate area. If you do not have or can not find a representative in your area, then contact the factory Warranty Administrator for assistance @ 1-800-447-0213.
4. Give a detailed description and nature of the problem. Also leave contact name(s), phone no. and/or e-mail address.
5. A claim will be processed and reviewed for warranty approval. The factory Warranty Administrator must authorize all Warranty Claims before repairs can be made.

Note: All work must be done by an authorized TrailMax warranty station. Should you choose to make repairs prior to approval, you could assume full responsibility for repairs.

6. Defective parts must be returned to Gem State Manufacturing at 1705 Industrial Way, Caldwell, Idaho, 83605, for evaluation unless otherwise instructed.
7. Please make sure you have followed the procedure all the way through, failure to do so could hold up final process of Warranty Claim and approval for payment.

Our ultimate goal is to retain satisfied customers. Your cooperation is appreciated, as we will process the claim as expeditiously as possible to get you back in service.